



PRODUCT SPECIFICATION

TFT-LCD MODULE

Model No:FRD700N50022-F-RT

For Customer's Acceptance	
Approved by	Comment

		Signature	Date
Prepared by			
Checked by			
Approved by			

深圳市福瑞达显示技术有限公司

地址：深圳市光明新区公明田寮第二工业区田荣路 68 号

Add:The 68th, Tianrong Road, Tianliao Community, Gongming Town, Guangming new district, shenzhen.

电话(Tel) : (0755) 33563743

传真(Fax) : (0755) 29351371

网址(Web) : www.fridalcd.com



Contents

No.	ITEM
1	Document Revision History
2	General Description
3	Outline Dimension
4	Interface Specification
5	Absolute Maximum Ratings
6	Electrical Specifications
7	Timing Characteristics
8	Power Supply Configuration
9	Optical Specification
10	Reliability Test Items
11	Precautions



1. Document Revision History :

DOCUMENT REVISION	DATE	DESCRIPTION	PREPARED BY
A	2018-08-02	First Release.	



2. General Description

No	Item	Specification	Remark
1	Screen Size	7.0inch	
2	Display Mode	Normally White	
3	Resolution	800×RGB×480	
4	Active Area	154.08*85.92	mm
5	Outline Dimension	164.9*100*6.77	mm
6	Viewing Direction	6 O' Clock	
7	Driver IC	EK9713CA+EK73002ACGB	
8	Interface	TTL	
9	Back Light	White Led3*9	
10	Touch Panel	RTP	



3. Outline Dimension

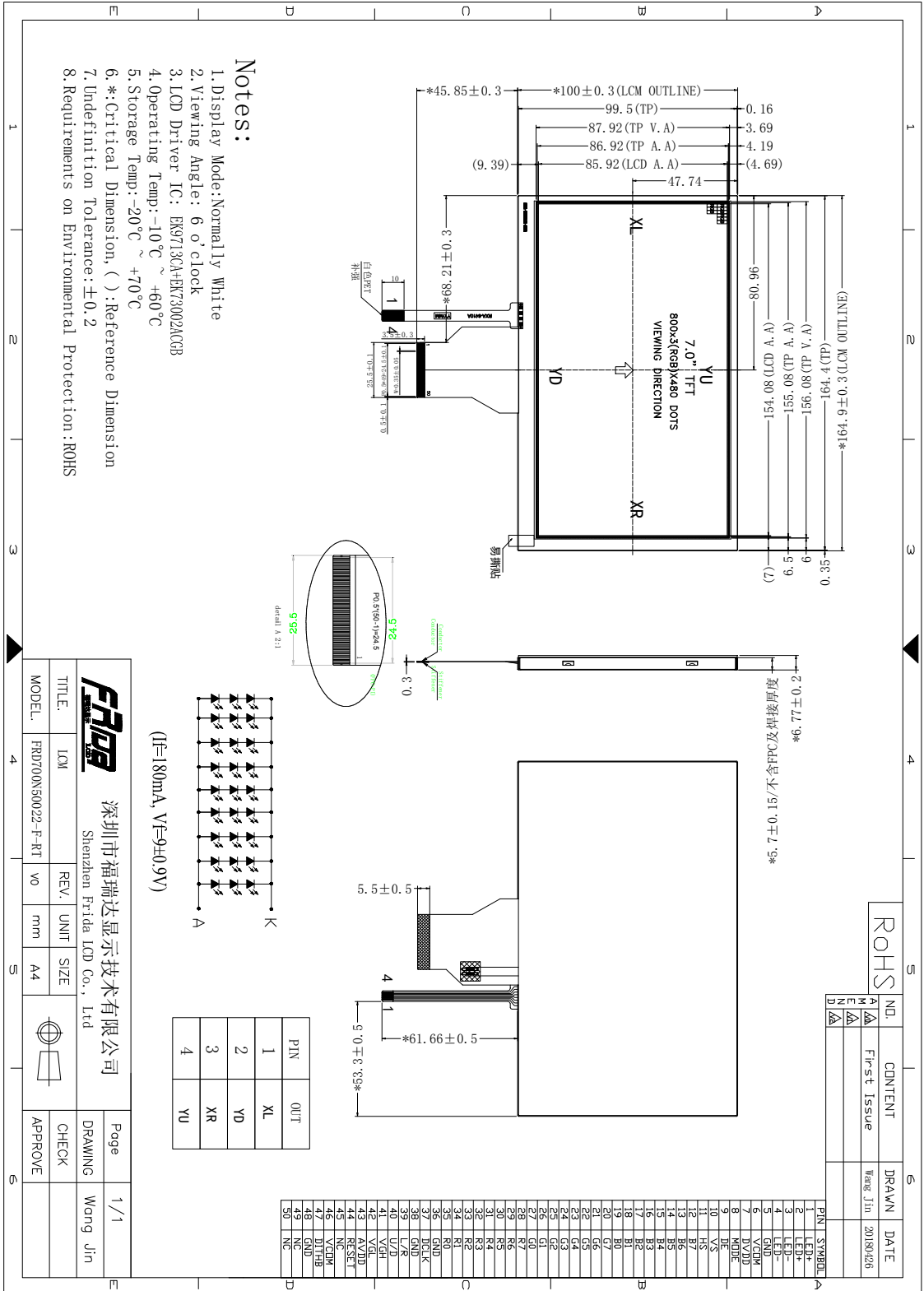



4. Interface Specification

Pin No	Symbol	Description	Note
1-2	LED+	Power Supply For LED Backlight Anode Input	
3-4	LED-	Power Supply For LED Backlight Cathode Input	
5	GND	Ground	
6	VCOM	Power supply for Common voltage.	
7	DVDD (VCC)	Power Supply For LCD	
8	MODE	DE/SYNC mode select	Note1
9	DE	Data enable signal for RGB interface operation.	
10	VS	Frame synchronous signal for RGB interface operation.	
11	HS	Line synchronous signal for RGB interface operation.	
12-19	B7-B0	Blue data (B7-LSB;B0-MSB)	
20-27	G7-G0	Green data (G7-LSB; G0-MSB)	
28-35	R7-R0	Red data (R7-LSB;R0-MSB)	
36	GND	System Ground	
37	DCLK	Dot Clock Signal For RGB Interface Operation	
38	GND	Ground	
39	L/R	Source Right or Left sequence control.Normally pull high.	Note2
40	U/D	Gate Up or Down scan control.Normally pull low.	Note2
41	VGH	Power supply for Positive Power for TFT	
42	VGL	Power supply for Negative Power for TFT	
43	AVDD	Power supply for Analog Circuit	
44	RESET	Reset Signal input pin.	
45	NC	Not Connect	
46	VCOM	Power supply for Common voltage.	
47	DITHB	Dithering function enable control.	Note3
48	GND	Ground	



49-50	NC	Not Connect	
-------	----	-------------	--

4.1 TP Interface Specification

Pin No	Symbol	Description	Note
1	XL	Touch panel left side	
2	YD	Touch panel down side	
3	XR	Touch panel right side	
4	YU	Touch panel up side	

Note1: DE / SYNC mode select. Normally pull high

H: DE mode.

L: HSD/VSD mode.

Note2: When L/R=" 0" , set right to left scan direction.

When L/R=" 1" , set left to right scan direction.

When U/D=" 0" , set top to bottom scan direction.

When U/D=" 1" , set bottom to top scan direction.

Note3: Dithering function enable control. Normally pull high

DITHB = "1" , Disable internal dithering function

DITHB = "0" , Enable internal dithering function



5. Absolute Maximum Ratings

Electrical Maximum Ratings – for IC Only

Parameter	Symbol	Min.	Max.	Unit	Note
Power supply voltage (DVDD)	DVDD	-0.5	+5.0	V	1
Power supply voltage (AVDD)	AVDD	-0.5	+15.0	V	1

Note:

- 1.DVDD,AVDD, GND must be maintained.
- 2.The modules may be destroyed if they are used beyond the absolute maximum ratings.

6. Electrical Specifications

At Ta = 25 °C, DVDD = 1.8V to 3.6V GND=0V.

Parameter	Symbol	Conditions	Min.	Typ.	Max.	Unit
Digital supply voltage	DVDD		1.8	3.3	3.6	V
Analog supply voltage	AVDD		6.5	-	13.5	V
TFT gate on voltage	VGH		14.5	15.0	15.5	V
TFT gate on voltage	VGL		-10.5	-10.0	-9.5	V
TFT common electrode voltage	VCOM		3.54	4.04	4.54	V
Supply current (Logic & LCD)	ICC		-	-	-	mA
Supply voltage of white LED backlight	VLED	Forward current =180mA Number of LED =27	8.1	9.0	9.9	V

Note: (1) Vcom must be adjusted to optimize display quality: cross-talk, contrast ratio and etc.

(2) VGH is TFT gate operating voltage

(3) VGL is TFT gate operating voltage

7. Timing Characteristics

7.1 AC Characteristics

5.6.1. For 800 × 480 panel

Horizontal input timing

Parameter		Symbol	Value			Unit
Horizontal display area		thd	800			DCLK
DCLK frequency		fclk	Min.	Typ.	Max.	MHz
			-	33.3	50	
1 Horizontal Line		th	862	1056	1200	DCLK
HSD pulse width	Min.	thpw				
	Typ.		-			
	Max.		40			
HSD Back Porch (Blanking)		thb	46	46	46	
HSD Front Porch		thfp	18	210	354	

Vertical input timing

Parameter	Symbol	Min.	Typ.	Max.	Unit
Vertical display area	hvd	480			H
VSD period time	tv	510	525	650	H
VSD pulse width	tvpw	1	-	20	H
VSD Back Porch (Blanking)	tvb	23	23	23	H
VSD Front Porch	tvfp	7	22	147	H

7.2 Timing Waveform

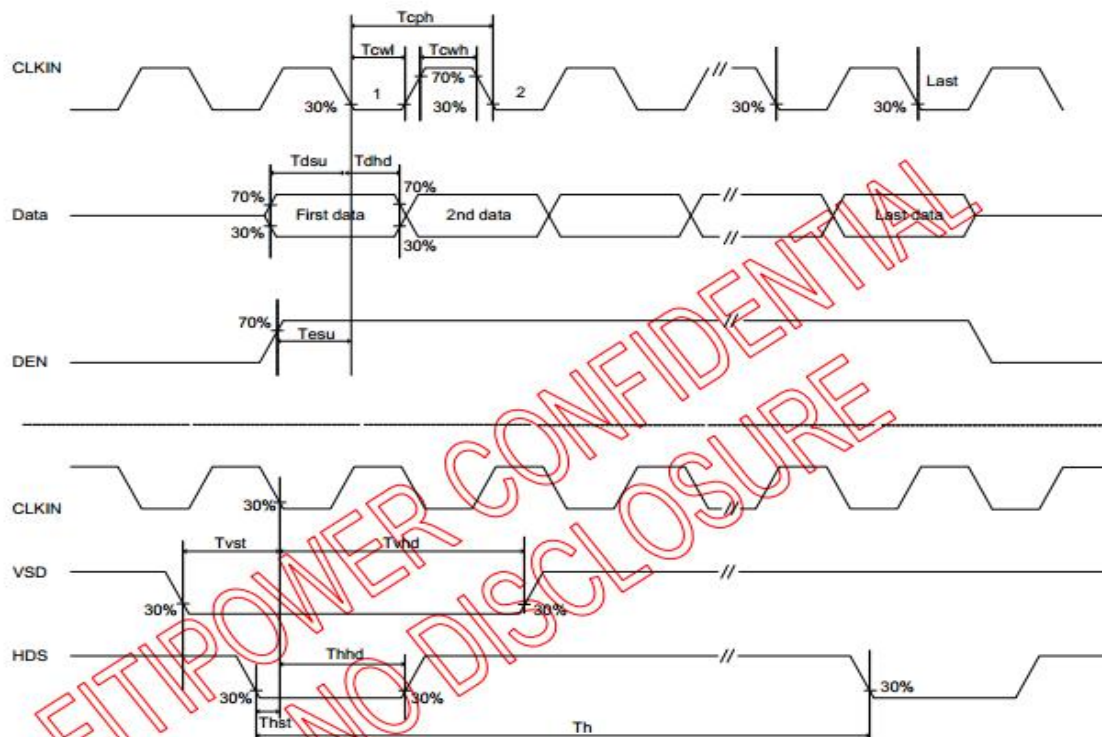

Input Clock and Data Timing Diagram

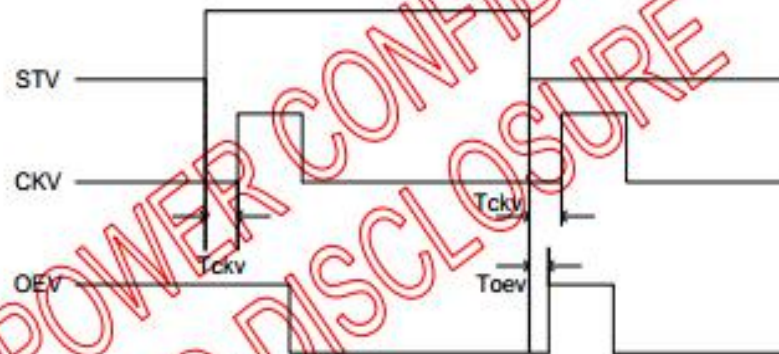
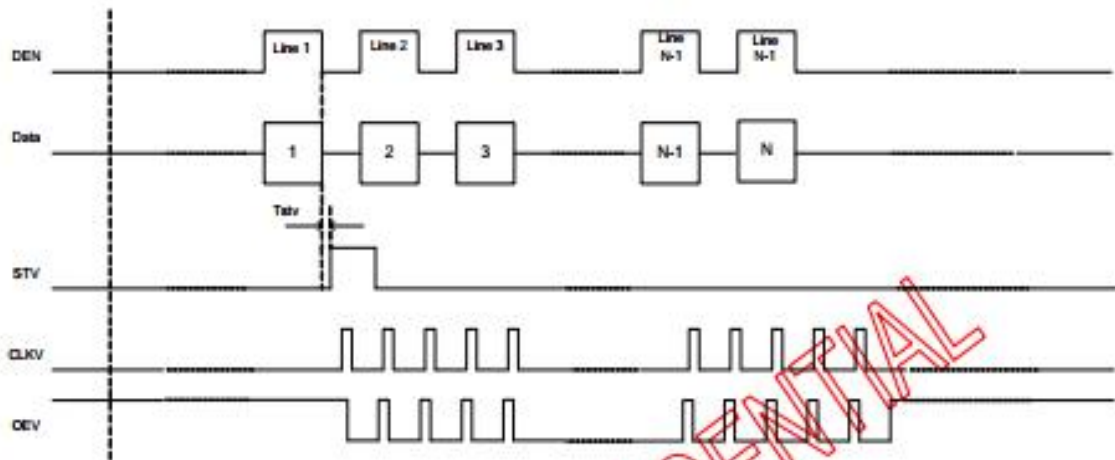

Vertical Timing Diagram DE

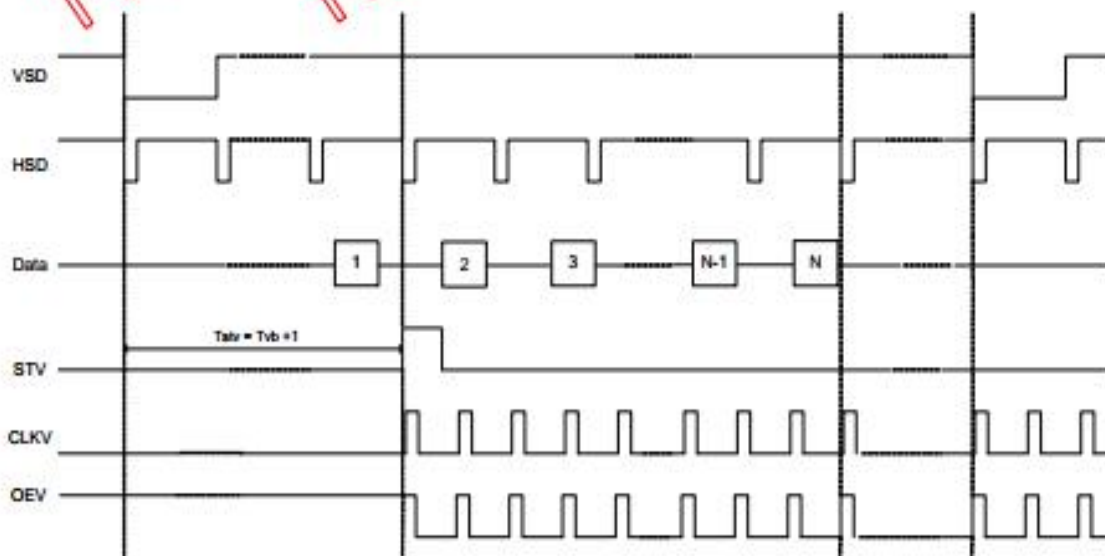

Vertical Timing Diagram HV

8. Power Supply Configuration

Power on/off sequence

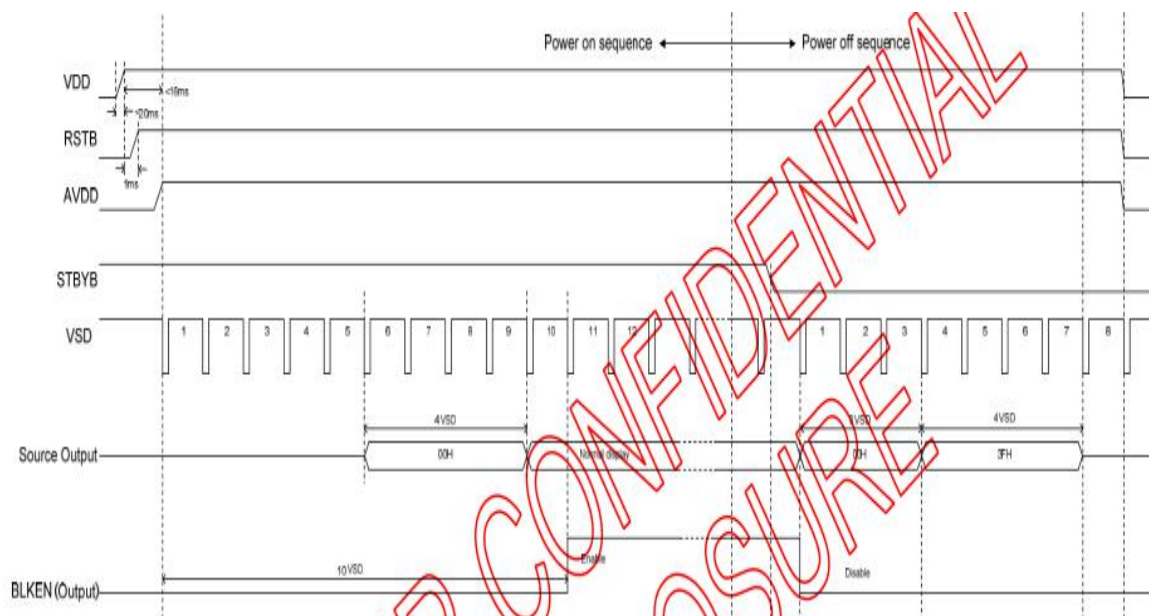

Power-On/Off Timing Sequence

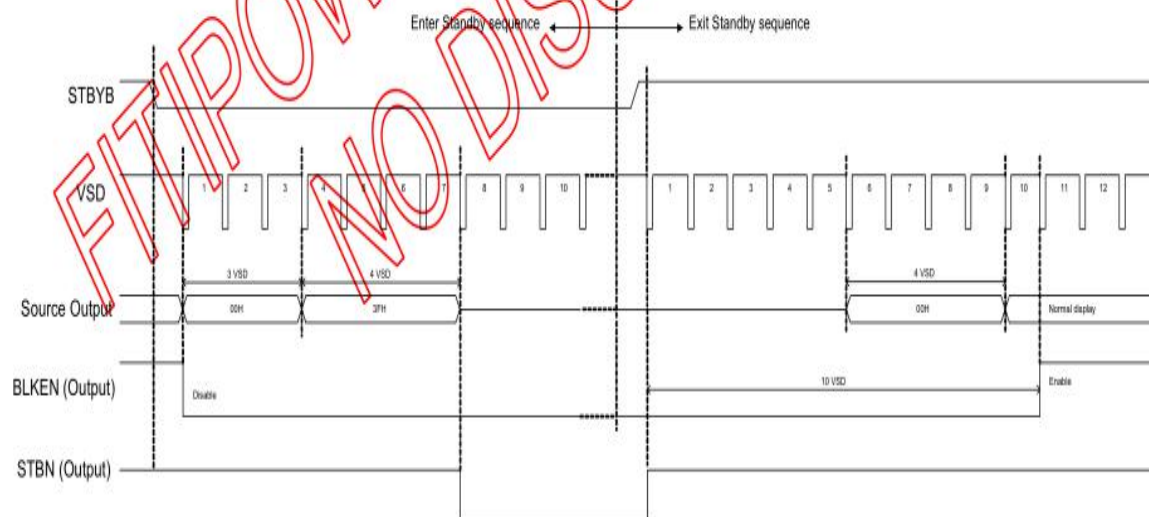

Enter and Exit Standby Mode Sequence

9.Optical Specification

Item 项目	Symbol 符号	Condition 条件	Min 最小值	Typ 典型值	Max 最大值	Unit 单位	Note 备注
Response time 响应时间	Tr+Tf	$\Theta=0^{\circ}$ $\emptyset=0^{\circ}$ Ta=25°C	-	25	-	ms	1
Contrast ratio 对比度	Cr		-	800	-	-	2
Color gamut 饱和度	S(%)		-	50	-	%	-
Luminance uniformity 均匀度	δ WHITE		80	-	-	%	3
Viewing angle range 视角范围	Θ_{x+}	CR \geq 10 Ta=25°C	-	70	-	deg	4
	Θ_{x-}		-	70	-	deg	
	Θ_{y+}		-	60	-	deg	
	Θ_{y-}		-	70	-	deg	
LCM Luminance LCM 亮度	Lv	$\Theta=0^{\circ}$ $\emptyset=0^{\circ}$ Ta=25°C	-	250	-	Cd/m ²	5
CIE (X,Y) Chromaticity 色度坐标	White(X)		0.27	0.30	0.33	-	6
	White(Y)		0.28	0.31	0.34	-	

Note1.Response time is the time required for the display to transition from White to black(Rise Time,Tr)and from black to white(Decay Time,Tf).For additional information see FIG1...

Note2.contrast Ratio(CR) is defined mathematically by the following formula ,For more information see FIG2.

Contrast Ratio(CR)=Average Surface Luminance with all white pixels/ Average Surface Luminance with all black pixels

Note3.The uniformity in surface luminance(WHITE) is determined by measuring luminance at each test position,and then dividing the maximum luminance of all white pixels by minimum luminance of all white pixels,For more information seeFIG2.

WHITE=Minimum Surface Luminance with all white pixels(P1,P2,.....)/Maximum Surface Luminance with all white pixels(P1,P2,.....)

Note4.Viewing angle is the angel at which contrast ratio is greater than a specific value.For TET module,the specific value of contrast ratio is 10.For monochrome and color stn module,the specific value of contrast ratio is2.The angles are determined for the horizontal or x axis and the vertical or y axis with respect to the z axis which is normal to the LCD surface.For more information see FIG3

Note5. Surface luminance is the LCD surface luminance with all white pixels,For more information see FIG2.

LV=Average Surface Luminance with all white pixels(P1,P2,.....)

Note6.CIE(X,Y)chromaticity is the Center point value.For more information see FIG2.

Note7.For Viewing angle and response time testing,the testing date is base on Autronic-Melchers' s ConScope.Series instruments.For contrast ratio,Surface Luminance,Luminance uniformity and CIE,the testing date is base on CS-2000 photo detector.

Note8.For TN type TFT transmissive module,Gray scale reverse occurs in the direction of panel viewing angle

FIG1. The definition of Response time

响应时间定义



FIG2. Measuring method for Contrast ratio,surface luminance,Luminance

uniformity,CIE(X,Y)chromaticity.

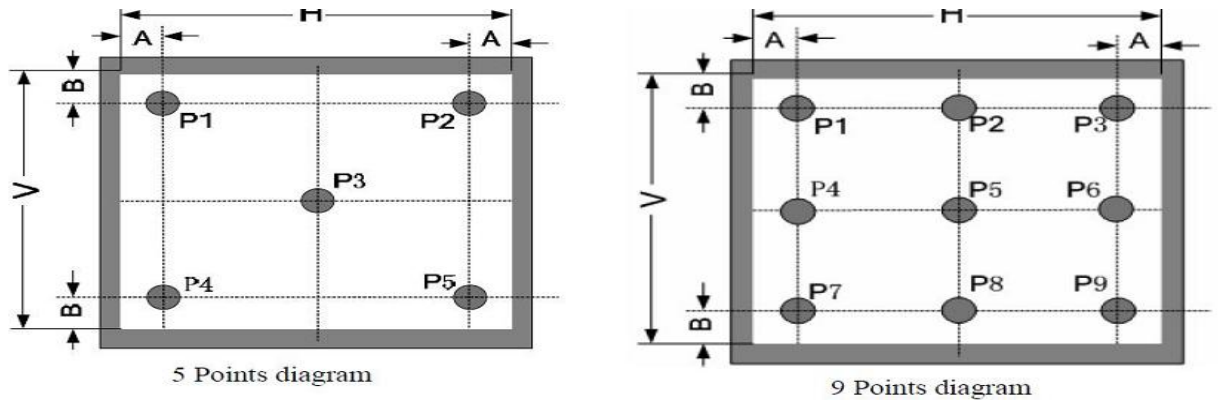
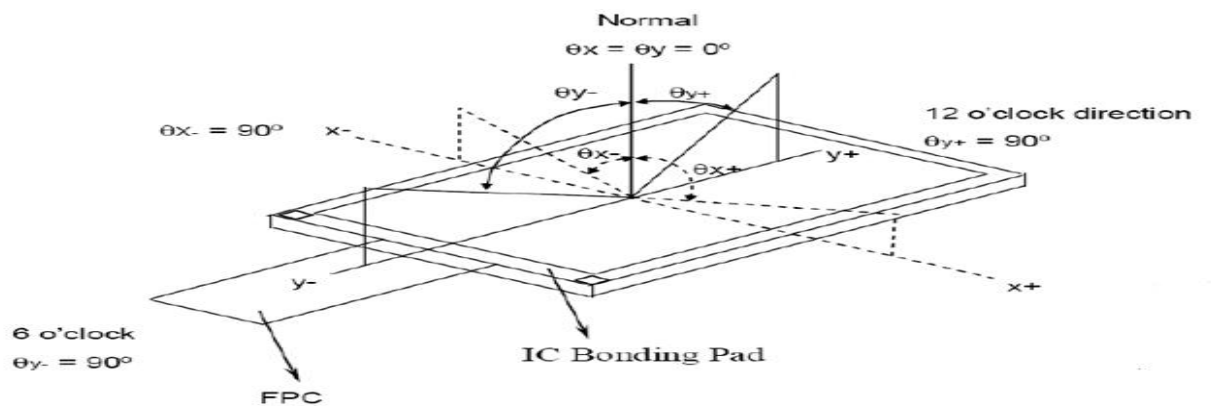

FIG3 The definition of viewing angle 视角定义





10. Reliability Test Items

Item	Test Condition	Criterion
High Temperature Storage	70 °C, 120 hrs	Note1,Note2
Low Temperature Storage	-20°C, 120 hrs	
High Temp. & High Humidity Storage	40 °C, 80% RH, 48hrs	
Thermal Shock (Static)	-30°C, 30 min /80, 30 min, 20 cycles	
High Temperature Operation	60 °C, 120 hrs	
Low temperature Operation	-10 °C, 120 hrs	

Note1: Evaluation should be tested after storage at room temperature for two hours.

Note2:

Pass: Normal display image no line defect.

Fail: No display image, or line defects.

Partial transformation of the module parts should be ignored.

11. Precautions

Please pay attentions to the followings as using the LCD module.

Handling

- (a) Do not apply strong mechanical stress like drop, shock or any force to LCD module. It may cause improper operation, even damage.
- (b) Because the polarizer is very fragile and easy to be damaged, do not hit, press or rub the display surface with hard materials.
- (c) Do not put heavy or hard material on the display surface, and do not stack LCD modules.
- (d) If the display surface is dirty, please wipe the surface softly with cotton swab or clean cloth.



- (e) Avoid using Ketone type materials (e.g. Acetone), Toluene, Ethyl acid or Methyl chloride to clean the display surface. It might damage the touch panel surface permanently. The recommended solvents are water and Isopropyl alcohol.
- (f) Wipe off water droplets or oil immediately.
- (g) Protect the LCD module from ESD. It will damage the LSI and the electronic circuit.
- (h) Do not touch the output pins directly with bare hands.
- (i) Do not disassemble the LCD module.
- (j) Do not lift the FPC of Touch Panel.

Storage

- (a) Do not leave the LCD modules in high temperature, especially in high humidity for a long time.
- (b) Do not expose the LCD modules to sunlight directly.
- (c) The liquid crystal is deteriorated by ultraviolet. Do not leave it in strong ultraviolet ray for a long time.
- (d) Avoid condensation of water. It may cause improper operation.
- (e) Please stack only up to the number stated on carton box for storage and transportation. Excessive weight will cause deformation and damage of carton box.

Operation

- (a) When mounting or dismounting the LCD modules, turn the power off.
- (b) Protect the LCD modules from electric shock.
- (c) The Driver IC control algorithms stated above should always obeyed to avoid damaging the LSI and electronic circuit.
- (d) Be careful to avoid mixing up the polarity of power supply for backlight.
- (e) Absolute maximum rating specified above has to be always kept in any case. Exceeding it may cause non-recoverable damage of electronic components or, nevertheless, burning.
- (f) When a static image is displayed for a long time, remnant image is likely to occur.
- (g) Be sure to avoid bending the FPC to an acute shape, it might break FPC.
- (h) Most of the touch screens have air vent to equalize the inside air pressure to the outside one. The air vent must be open and liquid contact must be avoided as the liquid may be

absorbed if the liquid is accumulated near the air vent.

- (i) For the fragility of ITO film, it should avoid to use too tapering pen as the input material.

Touch Panel Mounting Notes

- (a) If a cushion is used between bezel/housing and film must be choose as free as enough to absorb the expansion and contraction to avoid the distortion of film.
- (b) The cushion must be placed out of the Viewing Area.
- (c) Bezel/Housing edge must be posited between Key Area and Viewing Area. The edge enters the Key Area may cause unexpected input if the gap is too narrow or foreign particles like dusts exist between Bezel/Housing and ITO film.
- (d) Mounting example:

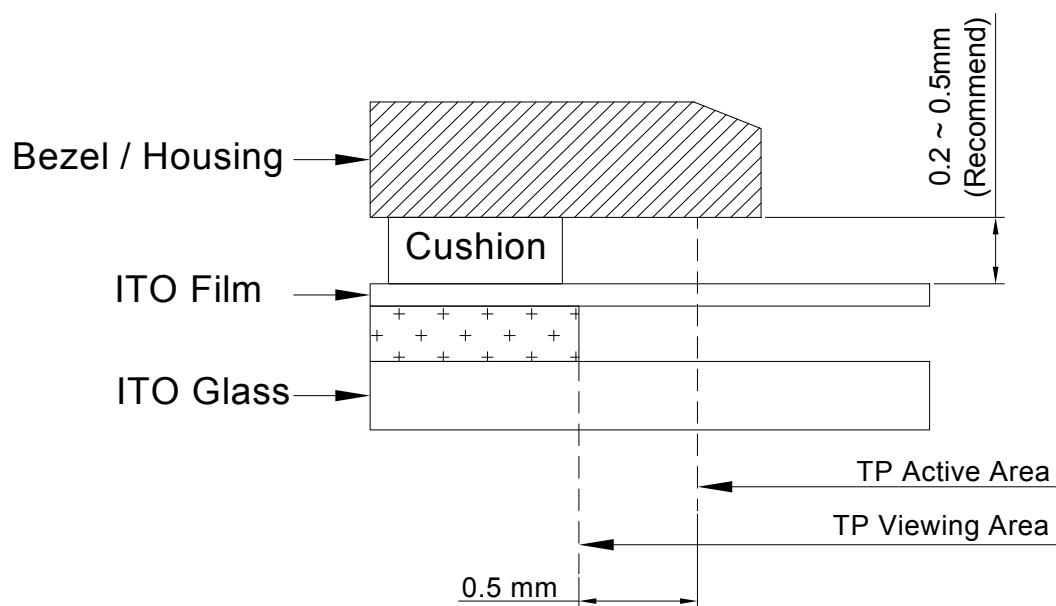

The corner part has conductivity. Do not touch any metal part after mounting.

Others

- a) If the liquid crystal leaks from the panel, it should be kept away from the eyes or mouth.
- b) For the fragility of polarizer, it is recommended to attach a transparent protective plate over the display surface.
- c) It is recommended to peel off the protection film on the polarizer slowly so that the electrostatic charge can be minimized.