



- Suitable for use in Custom Power Supplies
- Provides high voltage DC to TDK-Lambda's PH & PAF Power Modules
- Parallel operation on PF Series
- 12.7mm profile

PF Series

Rectifier & Power Factor Correction Modules

PF Features and Benefits

Features

- Low profile
- Parallel
- Power Factor corrected (PF)
- Operation up to 85°C

Benefits

- Assist system integration
- For higher power or N+1 operation
- Supports Global Use
- Operates in harsh environments

Specifications

Items		PF500A-360	PF1000A-360
AC Input Voltage range & Frequency	VAC	85-265 wide range	
Input Frequency	-	47 - 63Hz	
Output Voltage	VDC	360	
Output Power at 100/200VAC	W	504/756W	1008/1512W
Load Regulation	-	10V	
Line Regulation	-	5V typical	
Inrush Current	A	External pins provided connection for in rush resistor	
Efficiency (typ) at full load	%	90% (100VAC), 95% (200VAC)	
Power Factor	-	Meets EN61000-3-2 (0.95 typical)	
Overcurrent Protection	-	Converter shutdown	
Overvoltage Protection	V	390 - 400VDC, manual reset	
Thermal Shutdown	-	Shuts down Inverter, manual reset	
Inverter Good Signal	-	Yes, when inverter is operating correctly	
Enable Signal	-	Signal provided to enable "PH" DC-DC converters	
Parallel Connection	-	Single wire current share	
Auxiliary Output Voltage	-	Yes - see installation manual	
Operating Baseplate Temperature	°C	-20°C to +85°C (no derating)	
Storage Temperature	°C	-40°C to +85°C	
Cooling	-	Conduction (see installation manuals for heatsinks)	
Withstand Voltage	-	Input - Ground 3kVAC for 1 min	
Safety Agency Approvals	-	IEC/EN/UL/CSA60950-1, IEC/EN/UL/CSA62368-1 and CE Mark	
Weight	g	130	200
Size (WxHxD)	mm	See outline line drawings	
Warranty	yrs	2	

Notes: (Consult Installation Manual for detailed specifications, test methods and application notes)

Outline Drawing PF500A

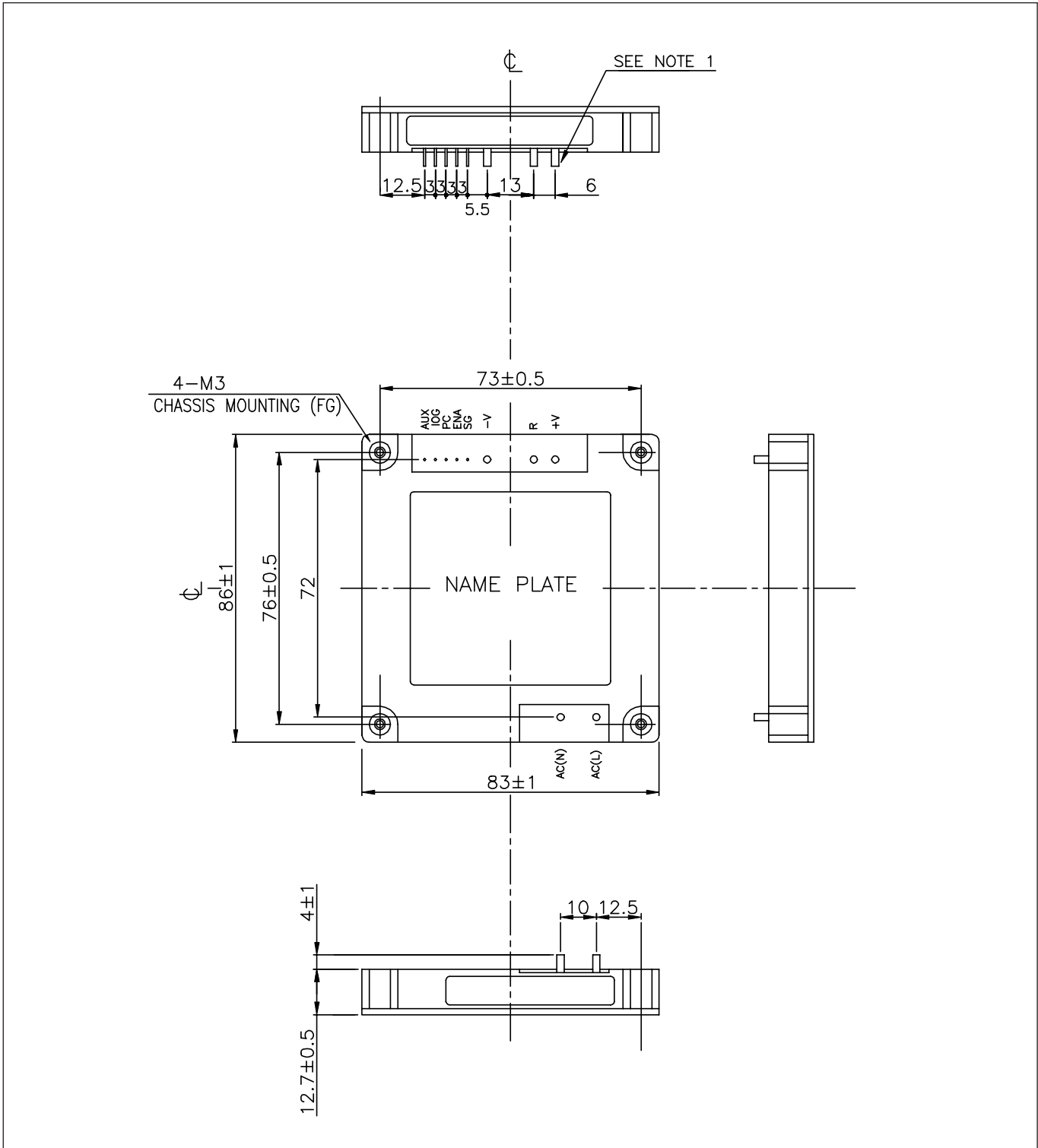

Outline Drawing PF1000A

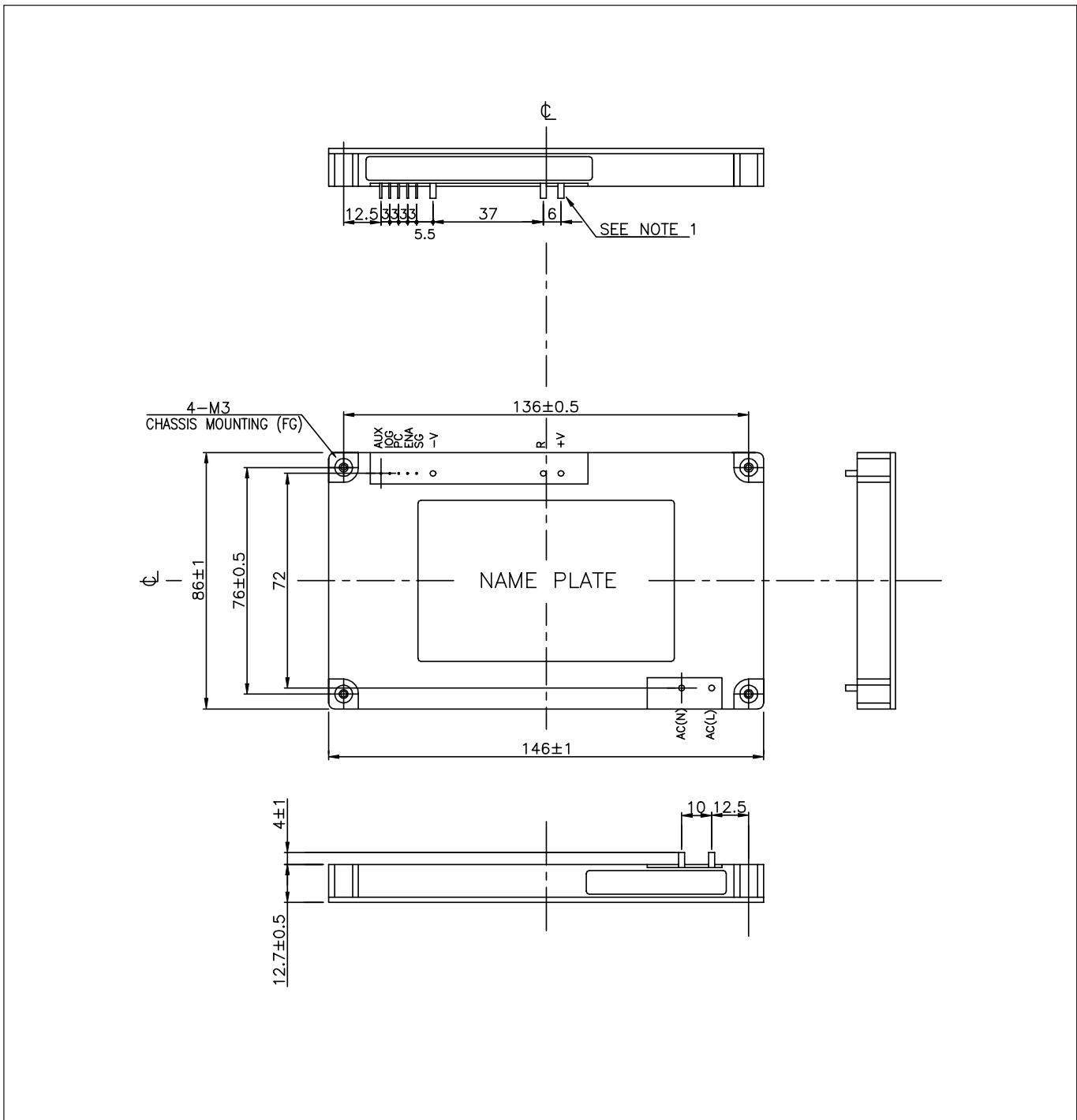



TDK-Lambda France SAS

3 Avenue du Canada
 Parc Technopolis
 Bâtiment Sigma
 91940 les Ulis
 France
 Tel: +33 1 60 12 71 65
 Fax: +33 1 60 12 71 66
france@fr.tdk-lambda.com
www.emea.lambda.tdk.com/fr



Italy Sales Office

Via Giacomo Matteotti 62
 20092 Cinisello Balsamo (MI)
 Italy
 Tel: +39 02 61 29 38 63
 Fax: +39 02 61 29 09 00
info.italia@it.tdk-lambda.com
www.emea.lambda.tdk.com/it



Netherlands

info@nl.tdk-lambda.com
www.emea.lambda.tdk.com/nl



TDK-Lambda Germany GmbH

Karl-Bold-Strasse 40
 77855 Achern
 Germany
 Tel: +49 7841 666 0
 Fax: +49 7841 5000
info.germany@de.tdk-lambda.com
www.emea.lambda.tdk.com/de



Austria Sales Office

Aredstrasse 22
 2544 Leobersdorf
 Austria
 Tel: +43 2256 655 84
 Fax: +43 2256 645 12
info@at.tdk-lambda.com
www.emea.lambda.tdk.com/at



Switzerland Sales Office

Eichtalstrasse 55
 8634 Hombrechtikon
 Switzerland
 Tel: +41 44 850 53 53
 Fax: +41 44 850 53 50
info@ch.tdk-lambda.com
www.emea.lambda.tdk.com/ch



Nordic Sales Office

Haderslevvej 36B
 DK-6000 Kolding
 Denmark
 Tel: +45 8853 8086
info@dk.tdk-lambda.com
www.emea.lambda.tdk.com/dk



TDK-Lambda UK Ltd.

Kingsley Avenue
 Ilfracombe
 Devon EX34 8ES
 United Kingdom
 Tel: +44 (0) 12 71 85 66 66
 Fax: +44 (0) 12 71 86 48 94
powersolutions@uk.tdk-lambda.com
www.emea.lambda.tdk.com/uk



TDK-Lambda Ltd.

1 Alexander Yanai
 Segula
 Petah-Tikva
 Israel
 Tel: +9 723 902 4333
 Fax: +9 723 902 4777
info@tdk-lambda.co.il
www.emea.lambda.tdk.com/il



C.I.S.

Commercial Support:
 Tel: +7 (495) 665 2627
Technical Support:
 Tel: +7 (812) 658 0463
info@tdk-lambda.ru
www.emea.lambda.tdk.com/ru

Local Distribution

