

12.3 MDL AV123Z7M-N17-58P0**(COG-VLBJT034-01)****Product Specification****Rev. A****HEFEI BOE XINSHENG OPTOELECTRONICS TECHNOLOGY**

REV.	ECN NO.	DESCRIPTION OF CHANGES	DATE	PREPARED
P0	-	Initial Release	2019.3.6	Zhongshan Wang

Contents

No.	Items	Page
1.0	General Description	4
2.0	Absolute Maximum Ratings	6
3.0	Electrical Specifications.	7
4.0	Optical Specifications.	8
5.0	Optical Test Appendix	10
6.0	Mechanical Characteristics	12
7.0	MDL Outline Dimension	13
8.0	Reliability Test	14
9.0	Interface Connection	15
10.0	Signal Specification	18
11.0	Power on/off Sequence	19
12.0	Package	21

1.0 GENERAL DESCRIPTION

1.1 Introduction

12.3inch module is a color active matrix TFT LCD module using amorphous silicon TFT's (Thin Film Transistors) as an active switching devices. It is a transmissive type display operating in the normal black. The TFT-LCD has a 12.3 inch diagonally measured active area with resolutions (1920 horizontal by 720 vertical pixel arrays). Each pixel is divided into RED, GREEN, BLUE dots which are arranged in vertical stripe and this panel can display 16.7M colors.

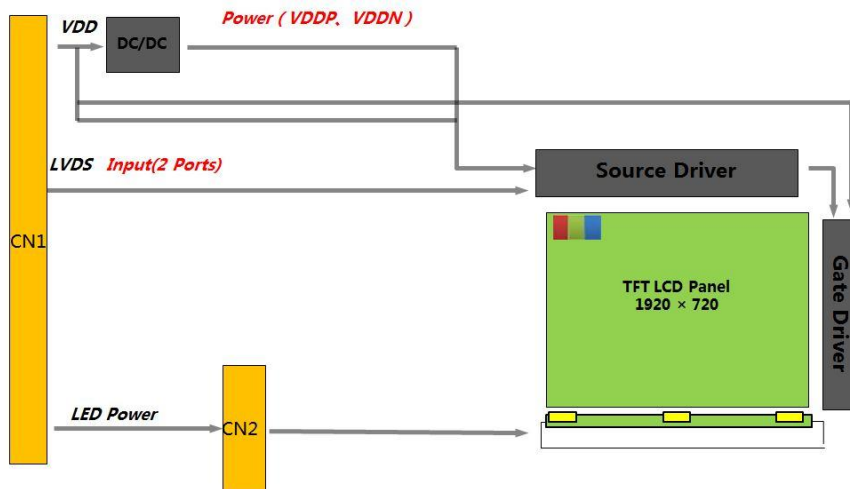

Figure 1-1 Block Diagram

1.2 Features

- Wide viewing angle (U/D/L/R) : 88/88/88/88
- Color Gamut : 72%
- Cell thickness : 1.0t
- LVDS Interface

1.3 Application

- Vehicle-mounted Production

1.4 General Specification

<Table 1-1 General Specifications>

Parameter	Specification	Unit	Remarks
Active area	292.032 (H) × 109.512 (V)	mm	8 : 3
Number of pixels	1920(H) × 720(V)	pixels	
Pixel pitch	0.1521(H) × RGB × 0.1521 (V)	mm	
Pixel arrangement	RGB Vertical stripe		
Display colors	16.7M	colors	
Color gamut	72%	%	Typ.
Display mode	Normally black		
Module outline	308(H) x 127 (V)	mm	
POL	AG		
Viewing Direction (Human Eye)	U/D/L/R Min 80/80/80/80 Typ 88/88/88/88		
Driver IC	3*HX8290-A-LT 1*HX8695-E-LT		Single gate 3S+1G IC方案

Note:

1. At the U/D/L/R direction, the viewing angle is same;
2. The TFT and CF Align Direction;



Figure 1-2 The TFT and CF Align Direction

2.0 ABSOLUTE MAXIMUM RATINGS

The followings are maximum values which, if exceed, may cause faulty operation or damage to the unit. The operational and non-operational maximum voltage and current values are listed in Table 2-1

< Table 2-1 Environment Absolute Maximum Ratings >

Parameter	Symbol	Min.	Max.	Unit	Remarks
LC operating Voltage *1)	V _{OP}	-	5.7	V	Ta=25+/-2°C
Operating Temperature (Humidity)	T _{OP}	-30	+85	°C	
	RH	-	90	%	At 60°C
Storage Temperature (Humidity)	T _{ST}	-40	+90	°C	
	RH	-	90	%	At 60°C

*1)Liquid Crystal driving voltage

Due to the characteristics of LC Material, this voltage varies with environmental temperature.

3.0 ELECTRICAL SPECIFICATIONS

3.1 Electrical Specifications

Ta=25+/-2°C

Parameter	Symbol	Values			Unit	Notes
		Min	Typ.	Max		
TFT Gate ON Voltage	VGH	16	-	18	V	
TFT Gate OFF Voltage	VGL	-15	-	-10.5	V	
TFT Common Electrode Voltage	VCOM	-3	-	0	V	TBD
Voltage of VCC		3	-	3.5	V	
Current of VCC		150	-	550	mA	
Supply current of LED backlight	Per string			100	mA	9 LED
Total Supply current of LED Backlight	I _{LED} Total			400	mA	4 strings
Supply voltage of LED backlight	Per string	23.9	27.5	30.2	V	4 strings

Notes :

- 1: AVDD should be set to satisfy the characteristic of LC .
- 2: VGH should be set to satisfy charging ratio of TFT pixel.
- 3 : VCOM should be adjusted to make the flicker level be minimum and optimize display quality.
- 4: Frame rate=60HZ
- 5: **BLU LED : Total 36 packages,4 strings(parallel),9 packages(Serial)**

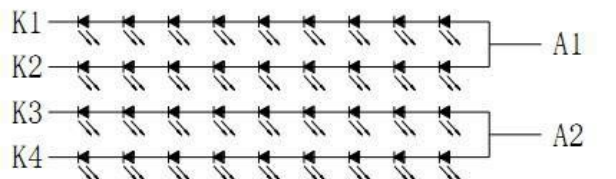

LED: JA. ZF3014W65P01

NTC: NCP18XH103F0SRB

Figure 3-1 LED&NTC Diagram

4.0 OPTICAL SPECIFICATION

4.1 Overview

The test of Optical specifications shall be measured in a dark room (ambient luminance \leq 1lux and temperature = $25\pm 2^\circ\text{C}$) with the equipment of Luminance meter system (Goniometer system and TOPCON BM-5) and test unit shall be located at an approximate distance 50cm from the LCD surface at a viewing angle of θ and Φ equal to 0° . The center of the measuring spot on the Display surface shall stay fixed.

The backlight should be operating for 30 minutes prior to measurement.

<Table 4-1 Optical Specifications>

Parameter		Symbol	Condition	Min.	Typ.	Max.	Unit	Remark
Viewing Angle range	Horizontal	Θ_3	CR > 10	80	88	-	Deg.	Note 1
		Θ_9		80	88	-	Deg.	
	Vertical	Θ_{12}		80	88	-	Deg.	
		Θ_6		80	88	-	Deg.	
Luminance Contrast ratio		CR	$\Theta = 0^\circ$ (Center) Normal Viewing Angle	-	1100	-		
White luminance uniformity		ΔY		70	80		%	Note 4
NTSC		%			72%			
White Chromaticity		x_w		Typ-0.03		0.2834	Typ+0.03	-
		y_w			0.3104	-		
Reproduction of color	Red	x_R			0.649	-		
		y_R			0.328	-		
	Green	x_G			0.317	-		
		y_G			0.625	-		
	Blue	x_B			0.146	-		
		y_B			0.058	-		
Response Time (Rising / Falling)		T_{RT}	25°C -20°C -30°C	-	-	25 200 350	ms	Note 6
BLU Derating		T	70°C	-	-	30%		F 5-4

Parameter	Condition	Min.	Typ.	Max.	Remark
Luminance	$\Theta = 0^\circ$ (Center) Normal Viewing Angle	-	1000	-	1 BEF (10°) + 1 DBEF
Flicker		-	-	-20dB	Interval Gray Pattern between L0 and L127, after 30s light up stably

Note :

- Viewing angle is the angle at which the contrast ratio is greater than 10. The viewing are determined for the horizontal or 3, 9 o'clock direction and the vertical or 6, 12 o'clock direction with respect to the optical axis which is normal to the LCD surface.
- Contrast measurements shall be made at viewing angle of $\theta = 0^\circ$ and at the center of the LCD surface. Luminance shall be measured with all pixels in the view field set first to white, then to the dark (black) state. (See FIGURE 1 shown in Appendix) Luminance Contrast Ratio (CR) is defined mathematically.

$$CR = \frac{\text{Luminance when displaying a white raster}}{\text{Luminance when displaying a black raster}}$$

- Center trans of white is defined as the LCD surface. Luminance shall be measured with all pixels in the view field set first to white. This measurement shall be taken at the locations shown in FIGURE 4 for a total of the measurements per display.
- The White luminance uniformity on LCD surface is then expressed as :
 $\Delta Y = (\text{Minimum Luminance of 9points} / \text{Maximum Luminance of 9points}) * 100$
- The color chromaticity coordinates specified in Table 4. shall be calculated from the spectral data measured with all pixels first in red, green, blue and white. Measurement condition is C - light source.
- The electro-optical response time measurements shall be made as FIGURE 5 shown in Appendix by switching the "data" input signal ON and OFF. The times needed for the transmittance to change from 10% to 90% is T_r , and 90% to 10% is T_f .

5.0 OPTICAL TEST APPENDIX

Figure 5-1 The Definition of Vth & Vsat

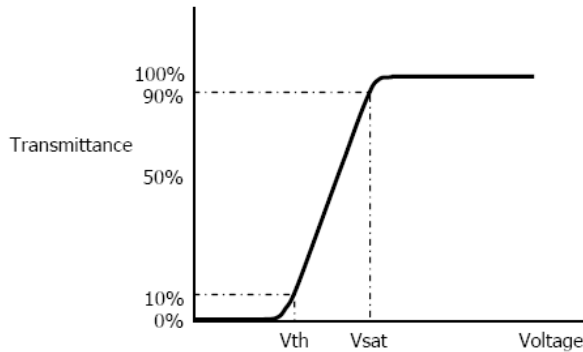

Figure 5-2 Measurement Set Up

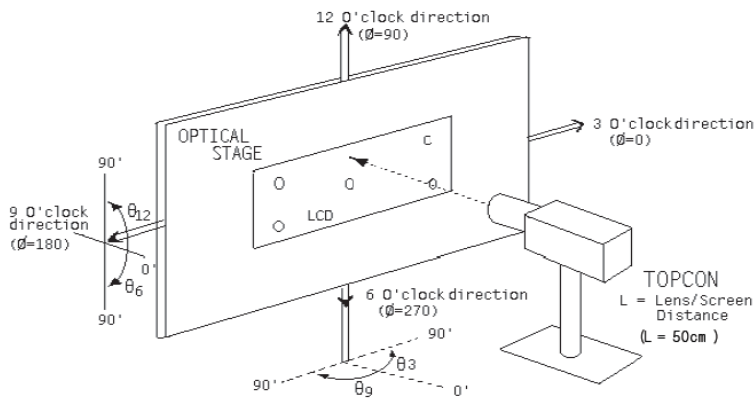

Figure 5-3 Response Time Testing

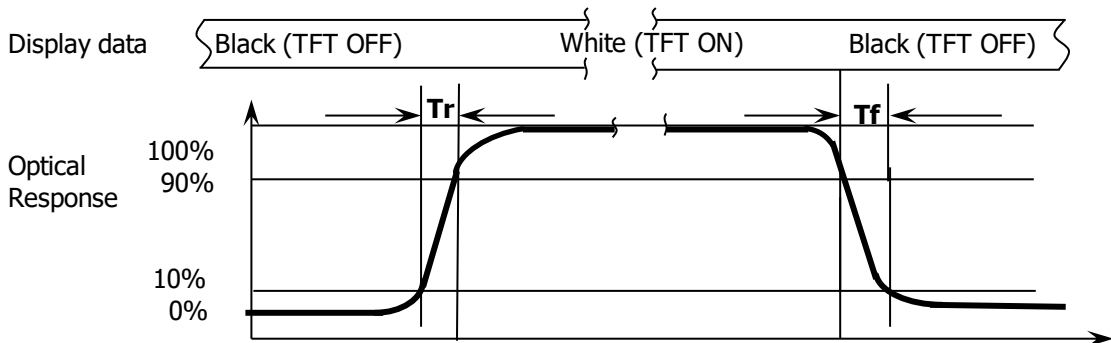
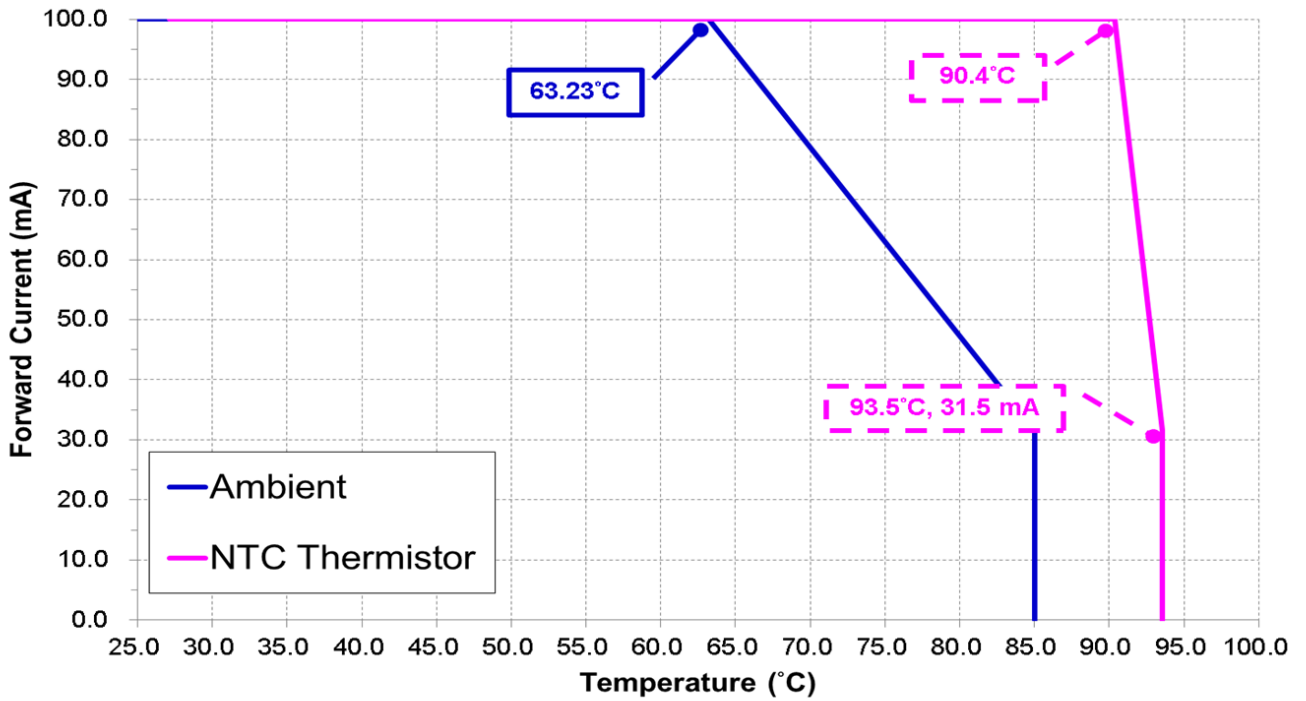

Figure 5-4 Derating.



6.0 MECHANICAL CHARACTERISTICS

6.1 Dimensional Requirements

Figure in next page shows mechanical outlines for the panel

<Table 6-1 Dimensional Parameters>

Parameter	Specification	Unit
Active Area	292.032 (H) × 109.512 (V)	mm
Number of pixels	1920(H) × 720(V)	Pixels
Pixel pitch	0.1521(H) × RGB × 0.1521 (V)	mm
Pixel arrangement	RGB Vertical stripe	
Display colors	16.7M	colors
Display mode	Normally black	
Module thickness	7.8 / 12.3	mm
Module outline	308x127	mm
AA-MDL outline L/R/U/D	9.568/6.4/6/11.488	mm

7.0 MDL Outline Dimension

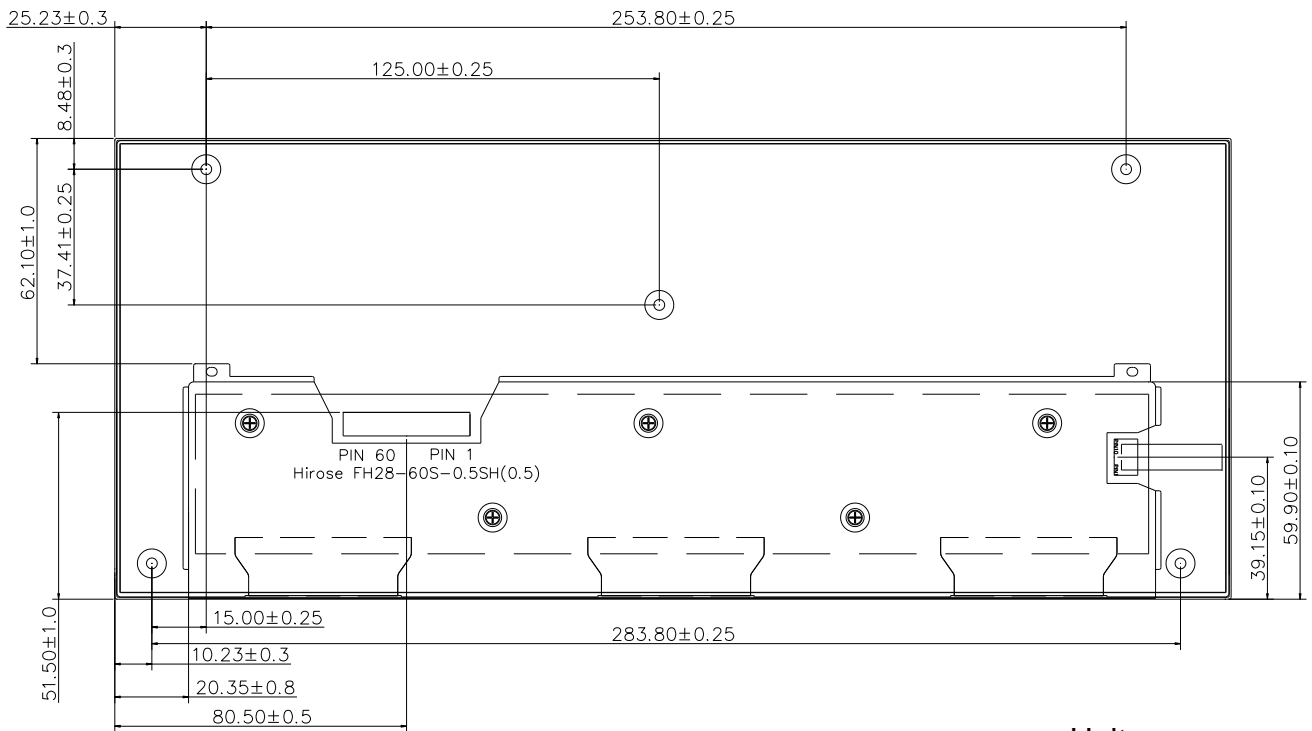
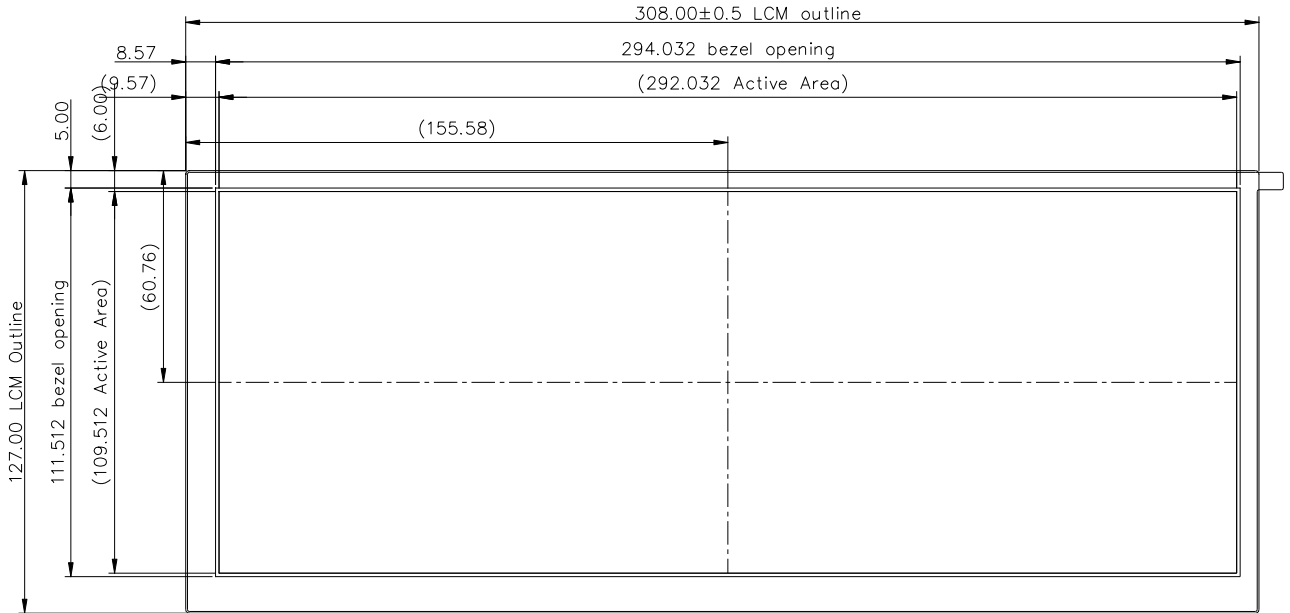

Unit : mm

SPEC. NUMBER

-

SPEC TITLE

AV123Z7M-N17-58P0

PAGE

13 OF 21

8.0 RELIABILITY TEST

<Table 8-1 Reliability test>

No	Test Items	Conditions	Remark
1	High temperature storage test	Ta = 90 °C, 500 hrs	
2	Low temperature storage test	Ta = -40 °C, 500 hrs	
3	High temperature operation test	Ta = 85°C, 500 hrs	
4	Low temperature operation test	Ta = -30 °C, 500 hrs	
5	High temperature & high humidity operation test	Ta = 65 °C, 90%RH, 500 hrs	
6	Thermal shock	Ta = -30 °C ↔ 85 °C (0.5 hr), 100 cycle	Non-operation
7	Image Sticking	5*5 Pattern, 2hrs 25°C check pattern Gray 127, Spec:≤L2 after 5 mins, the mura must be disappeared completely	
8	ESD test	Air Voltage: ± 15KV Contact Voltage: ± 8KV R: 330Ω C: 150pF 5 time	Note
9	Vibration Test	Random: 0.015G ² /Hz, 5~200Hz -6dB/Octave, 200~400Hz XYZ 8H	

Note

Class B, 有异常而可恢复, 比如闪屏

因为整机ESD水平不仅与模组相关, 也与系统相关。此处承诺配合客户整机达到要求, 如需要将进行ESD改善。

9.0 INTERFACE CONNECTION

9.1 The LCD Module Electrical Interface Connection

The Recommended connector is [Hirose FH28-60S-0.5SH\(0.5\)](#)

The connector interface pin assignments are listed in Table 9-1

Table 9-1 Pin Assignments for the LCD Connector

PIN	SYMBOL	Description	Remark
1	GND	Ground	
2	VCC	Power Supply	
3	VCC	Power Supply	
4	GND	Ground	
5	ORXIN0-	LVDS Receiver Signal(-)	
6	ORXIN0+	LVDS Receiver Signal(+)	
7	GND	Ground	
8	ORXIN1-	LVDS Receiver Signal(-)	
9	ORXIN1+	LVDS Receiver Signal(+)	
10	GND	Ground	
11	ORXIN2-	LVDS Receiver Signal(-)	
12	ORXIN2+	LVDS Receiver Signal(+)	
13	GND	Ground	
14	ORXCLKIN-	LVDS Receiver Signal(-)	
15	ORXCLKIN+	LVDS Receiver Signal(+)	
16	GND	Ground	
17	ORXIN3-	LVDS Receiver Signal(-)	
18	ORXIN3+	LVDS Receiver Signal(+)	
19	GND	Ground	
20	ERXIN0-	LVDS Receiver Signal(-)	
21	ERXIN0+	LVDS Receiver Signal(+)	
22	GND	Ground	
23	ERXIN1-	LVDS Receiver Signal(-)	
24	ERXIN1+	LVDS Receiver Signal(+)	
25	GND	Ground	

PIN	SYMBOL	Description	Remark
26	ERXIN2-	LVDS Receiver Signal(-)	
27	ERXIN2+	LVDS Receiver Signal(+)	
28	GND	Ground	
29	ERXCLKIN-	LVDS Receiver Signal(-)	
30	ERXCLKIN+	LVDS Receiver Signal(+)	
31	GND	Ground	
32	ERXIN3-	LVDS Receiver Signal(-)	
33	ERXIN3+	LVDS Receiver Signal(+)	
34	GND	Ground	
35	NC	NO CONNECTION	
36	RESET	RESET Signal	
37	STBYB	STBYB Signal	
38	SCL	SPI Signal	
39	SDA	SPI Signal	
40	CSB	SPI Signal	
41	ATREN	Enable auto reload Single	
42	NC	NO CONNECTION	
43	VOTP	OTP Voltage	
44	GND	Ground	
45	LR	Horizontal shift direction	Note 1
46	TB	Vertical shift direction	Note 1
47	FAULT	Fault dection	
48	NC	NO CONNECTION	
49	LEDA	Power Supply of LED	
50	LEDA	Power Supply of LED	

PIN	SYMBOL	Description	Remark
51	NC	NO CONNECTION	
52	NC	NO CONNECTION	
53	LEDK1	Ground of LED	
54	LEDK2	Ground of LED	
55	LEDK3	Ground of LED	
56	LEDK4	Ground of LED	
57	NC	NO CONNECTION	
58	NTC_A	Thermistor Sensor	
59	NC	NO CONNECTION	
60	NTC_K	Thermistor Sensor	

Note 1:

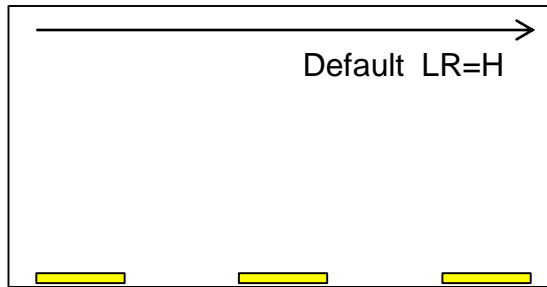

10.0 SIGNAL SPECIFICATION

10.1 LVDS Signal Timing

Table 10-1 LVDS Signal Timing

Parameter	Symbol	Min.	Typ.	Max.	Unit	Condition
Clock frequency	RxFCLK		44.1		MHz	
Horizontal Display Area	thd	960			DCLK	
HS Period	th	989	992	1005	DCLK	
HS Blanking	Thb+thfp	32			DCLK	
Vertical Display Area	tvd	720			TH	
VS Period	tv	730	741	753	TH	
VS Blanking	Tvbp+tvfp	21			TH	
Input data skew margin	TRSKM	400			ps	
Clock high time	TLVCH	2.45	3	4.55	ns	
Clock low time	TLVCL	2.45	4	4.55	ns	
PLL wake-up time	TenPLL			150	us	

10.2 Signal Format

Table 10-2 Signal Format

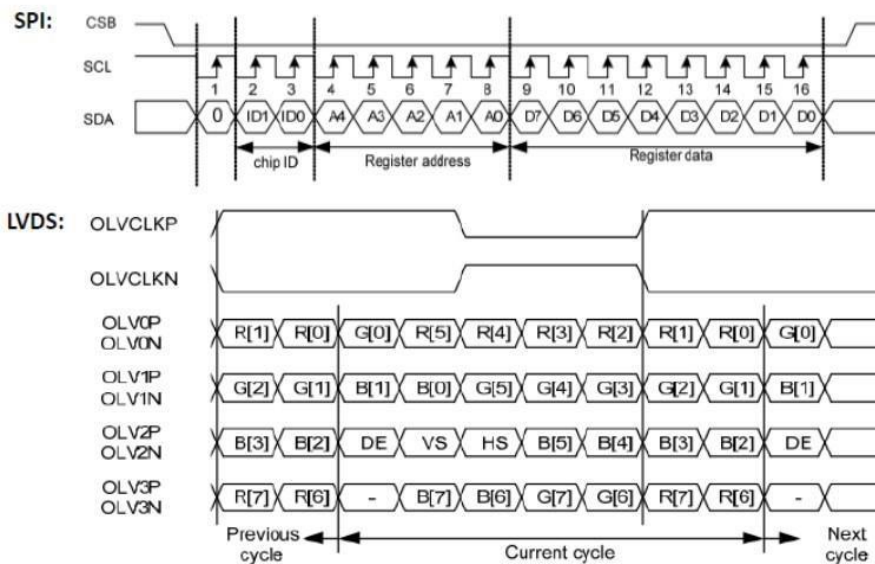

11.0 POWER ON/OFF SEQUENCE

11.1 POWER ON SEQUENCE

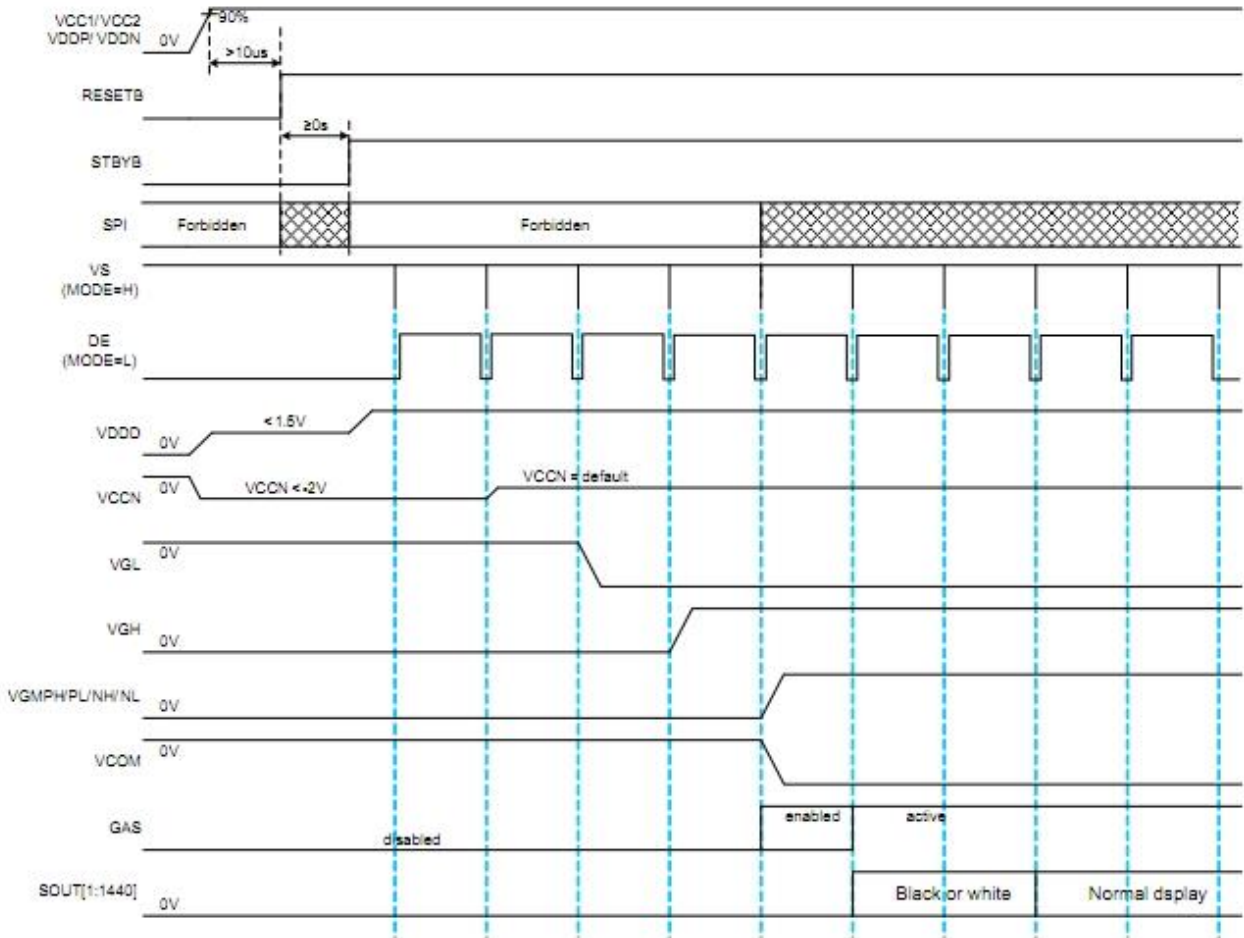

11.0 POWER ON/OFF SEQUENCE

11.2 POWER OFF SEQUENCE

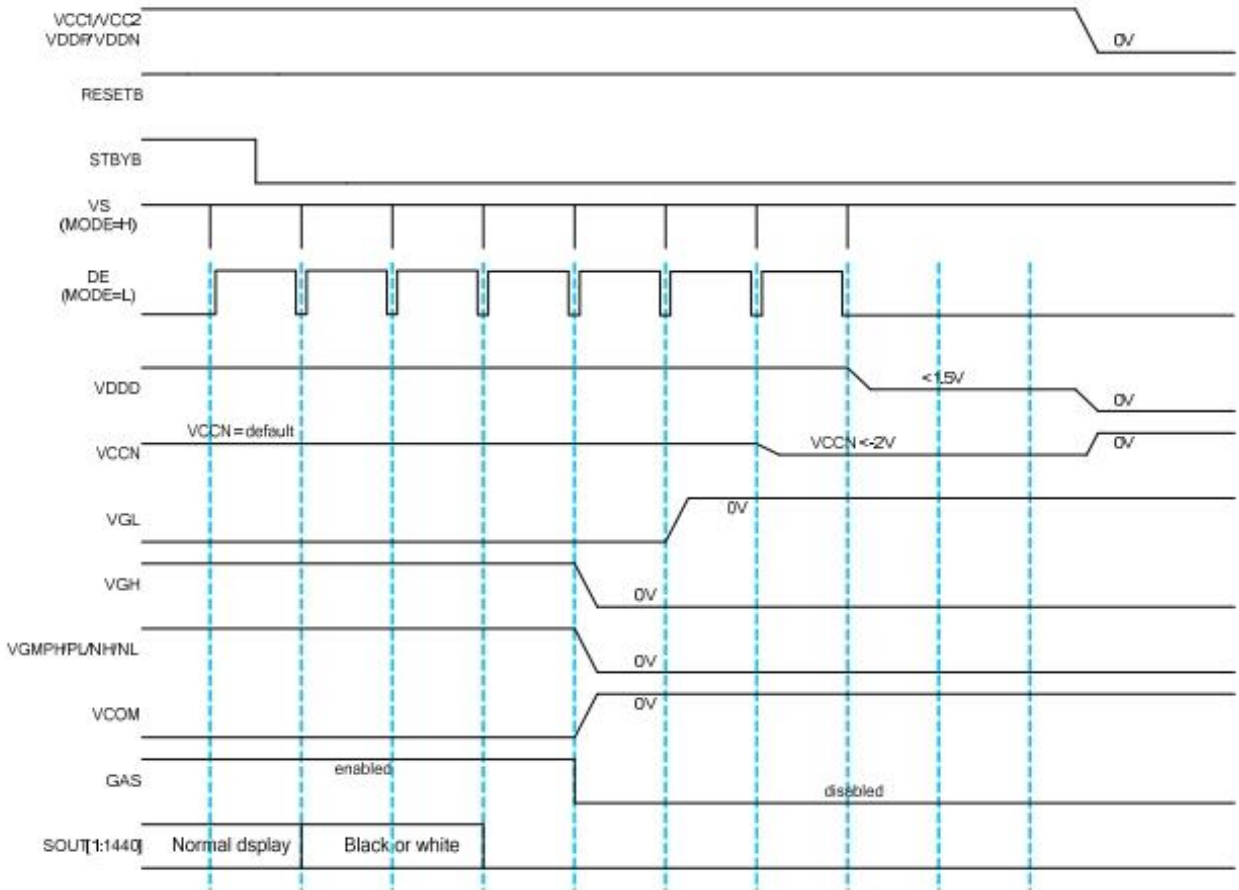

12. Package

12.1. Packing Description

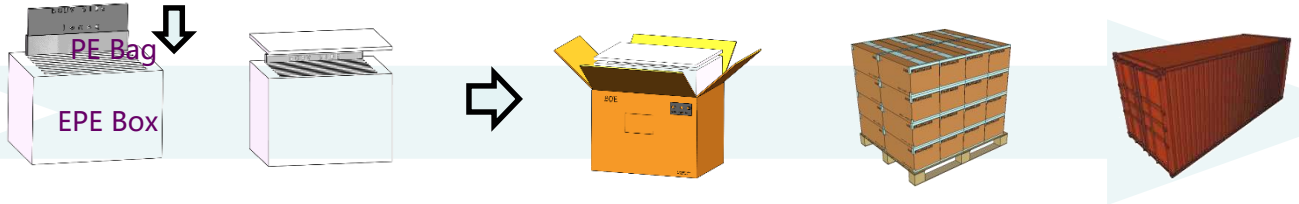

1-. 将1 pcs 贴好硬保的Panel放入PE Bag

注意: 1.PCBA侧统一朝下

2.PE Bag开口向显示面折叠, 再使用胶纸粘合折叠处

2-. 将1pcs产品横向插入卡槽内

- 将1pcs EPE Cover盖在 EPE Bottom 上, 将整体装入Box

-容量: 7pcs MDL /EPE Box

3-. 每个Pallet上4排2列码放,

共堆码4层Box, 共计32ea Box

- Pallet外进行护角&缠膜包装

- 容量: 224pcs Panel / Pallet

4-. 双排双层码放

-容量: 50EA Pallet/Truck,

11200 pcs Panel/Truck