

TFT COLOR LCD MODULE

NL192108BC18-06F

40cm (15.6 Type)

FHD

eDP interface

DATA SHEET 

DOD-PP-3097 (2nd edition)

**This DATA SHEET is updated document from
DATA SHEET DOD-PP-2577(1)**

**All information is subject to change without notice.
Please confirm the sales representative before
starting to design your system.**

INTRODUCTION

The Copyright to this document belongs to Tianma Japan, Ltd. (hereinafter called " TMJ "). No part of this document will be used, reproduced or copied without prior written consent of TMJ.

TMJ does and will not assume any liability for infringement of patents, copyrights or other intellectual property rights of any third party arising out of or in connection with application of the products described herein except for that directly attributable to mechanisms and workmanship thereof. No license, express or implied, is granted under any patent, copyright or other intellectual property right of TMJ.

Some electronic products would fail or malfunction at a certain rate. In spite of every effort to enhance reliability of products by TMJ, the possibility of failures and malfunction might not be avoided entirely. To prevent the risks of damage to death, human bodily injury or other property arising out thereof or in connection therewith, each customer is required to take sufficient measures in its safety designs and plans including, but not limited to, redundant system, fire-containment and anti-failure.

The products are classified into three grades: "**Standard**", "**Special**", and "**Specific**".

Each quality grade is designed for applications described below. Any customer who intends to use a product for application other than that of Standard is required to contact TMJ sales representative in advance.

The **Standard**: Applications as any failure, malfunction or error of the products are free from any damage to death, human bodily injury or other property (Products Safety Issue) and not related the safety of the public (Social Issues), like general electric devices.

Examples: Office equipment, audio and visual equipment, communication equipment, test and measurement equipment, personal electronic equipment, home electronic appliances, car navigation system (with no vehicle control functions), seat entertainment monitor for vehicles and airplanes, fish finder (except marine radar integrated type), PDA, etc.

The **Special**: Applications as any failure, malfunction or error of the products might directly cause any damage to death, human bodily injury or other property (Products Safety Issue) and the safety of the public (Social Issues) and required high level reliability by conventional wisdom.

Examples: Vehicle/train/ship control system, traffic signals system, traffic information control system, air traffic control system, surgery/operation equipment monitor, disaster/crime prevention system, etc.

The **Specific**: Applications as any failure, malfunction or error of the products might severe cause any damage to death, human bodily injury or other property (Products Safety Issue) and the safety of the public (Social Issues) and developed, designed and manufactured in accordance with the standards or quality assurance program designated by the customer who requires extremely high level reliability and quality.

Examples: Aerospace system (except seat entertainment monitor), nuclear control system, life support system, etc.

The quality grade of this product is the "**Standard**" unless otherwise specified in this document.

CONTENTS

INTRODUCTION	2
1. OUTLINE.....	4
1.1 STRUCTURE AND PRINCIPLE	4
1.2 APPLICATION	4
1.3 FEATURES	4
2. GENERAL SPECIFICATIONS.....	5
3. BLOCK DIAGRAM.....	6
4. DETAILED SPECIFICATIONS.....	8
4.1 MECHANICAL SPECIFICATIONS	8
4.2 ABSOLUTE MAXIMUM RATINGS.....	8
4.3 ELECTRICAL CHARACTERISTICS.....	9
4.3.1 LCD panel signal processing board	9
4.3.2 Backlight.....	9
4.3.3 Fuse.....	9
4.4 POWER SUPPLY VOLTAGE SEQUENCE.....	10
4.5 CONNECTIONS AND FUNCTIONS FOR INTERFACE PINS	11
4.5.1 LCD panel signal processing board	11
4.5.2 Backlight.....	12
4.5.3 Positions of socket	12
4.6 DISPLAY COLORS AND INPUT DATA SIGNALS.....	13
4.7 INPUT DATA SIGNALS AND DISPLAY POSITIONS	14
4.8 eDP SIGNAL TIMING SPECIFICATIONS	15
4.8.1 Display Port main link signal.....	15
4.8.2 Display Port HPD signal.....	15
4.8.3 Display port AUX signal	15
4.9 INPUT SIGNAL TIMINGS	16
4.9.1 Outline of input signal timings	16
4.9.2 Timing characteristics.....	17
4.9.3 Input signal timing chart	17
4.10 OPTICS.....	18
4.10.1 Optical characteristics	18
4.10.2 Definition of contrast ratio.....	19
4.10.3 Definition of luminance uniformity	19
4.10.4 Definition of response times	19
4.10.5 Definition of viewing angles.....	19
5. ESTIMATED LUMINANCE LIFETIME.....	20
6. RELIABILITY TESTS	21
7. PRECAUTIONS	22
7.1 MEANING OF CAUTION SIGNS	22
7.2 CAUTIONS	22
7.3 ATTENTIONS.....	22
7.3.1 Handling of the product	22
7.3.2 Environment.....	23
7.3.3 Characteristics.....	23
7.3.4 Others.....	24
8. OUTLINE DRAWINGS.....	25
8.1 FRONT VIEW	25
8.2 REAR VIEW	26

1. OUTLINE

1.1 STRUCTURE AND PRINCIPLE

Color LCD module NL192108BC18-06F is composed of the amorphous silicon thin film transistor liquid crystal display (a-Si TFT LCD) panel structure with driver LSIs for driving the TFT (Thin Film Transistor) array and a backlight.

The a-Si TFT LCD panel structure is injected liquid crystal material into a narrow gap between the TFT array glass substrate and a color-filter glass substrate.

Color (Red, Green, Blue) data signals from a host system (e.g. signal generator, etc.) are modulated into best form for active matrix system by a signal processing board, and sent to the driver LSIs which drive the individual TFT arrays.

The TFT array as an electro-optical switch regulates the amount of transmitted light from the backlight assembly, when it is controlled by data signals. Color images are created by regulating the amount of transmitted light through the TFT array of red, green and blue dots.

1.2 APPLICATION

- For industrial use

1.3 FEATURES



- Ultra wide viewing angle (Super Fine TFT (SFT))
- High resolution
- Ultra high luminance
- High contrast
- Wide temperature range
- eDP interface
- Narrow border
- LED backlight
- Acquisition product for UL60950-1/CSA C22.2 No.60950-1-03 (File number: E170632)
- Compliance with the European RoHS directive (2011/65/EU)

2. GENERAL SPECIFICATIONS

Display area	344.16 (H) × 193.59 (V) mm
Diagonal size of display	40cm (15.6 inches)
Drive system	a-Si TFT active matrix
Display color	16,777,216 colors
Pixel	1,920 (H) × 1,080 (V) pixels
Pixel arrangement	RGB (Red dot, Green dot, Blue dot) vertical stripe
Dot pitch	0.05975 (H) × 0.17925 (V) mm
Pixel pitch	0.17925 (H) × 0.17925 (V) mm
Module size	363.8 (W) × 215.9 (H) × 15.7 D mm (typ.)
Weight	1,050g (typ.)
Contrast ratio	750:1 (typ.)
Viewing angle	At the contrast ratio $\geq 10:1$ <ul style="list-style-type: none"> • Horizontal: Right side 88° (typ.), Left side 88° (typ.) • Vertical: Up side 88° (typ.), Down side 88° (typ.)
Designed viewing direction	• Viewing angle with optimum grayscale ($\gamma=2.2$): Normal axis (perpendicular)
Polarizer surface	Antiglare
Polarizer pencil-hardness	3H (min.) [by JIS K5600]
Color gamut	At LCD panel center 40% (typ.) [against NTSC color space]
Response time	$T_{on}+T_{off}$ (10% \leftrightarrow 90%) 30ms (typ.)
Luminance	At $I_L=65mA/One\ circuit$ 1,500cd/m ² (typ.)
Signal system	eDP 2 lanes, 2.7Gbps [8-bit digital signals for data of RGB colors, Dot clock (CLK), Data enable (DE)]
Power supply voltage	LCD panel signal processing board: 3.3V
Backlight	LED backlight
Power consumption	At $I_L=65mA/One\ circuit$, Checkered flag pattern 23.3W (typ.)

3. BLOCK DIAGRAM

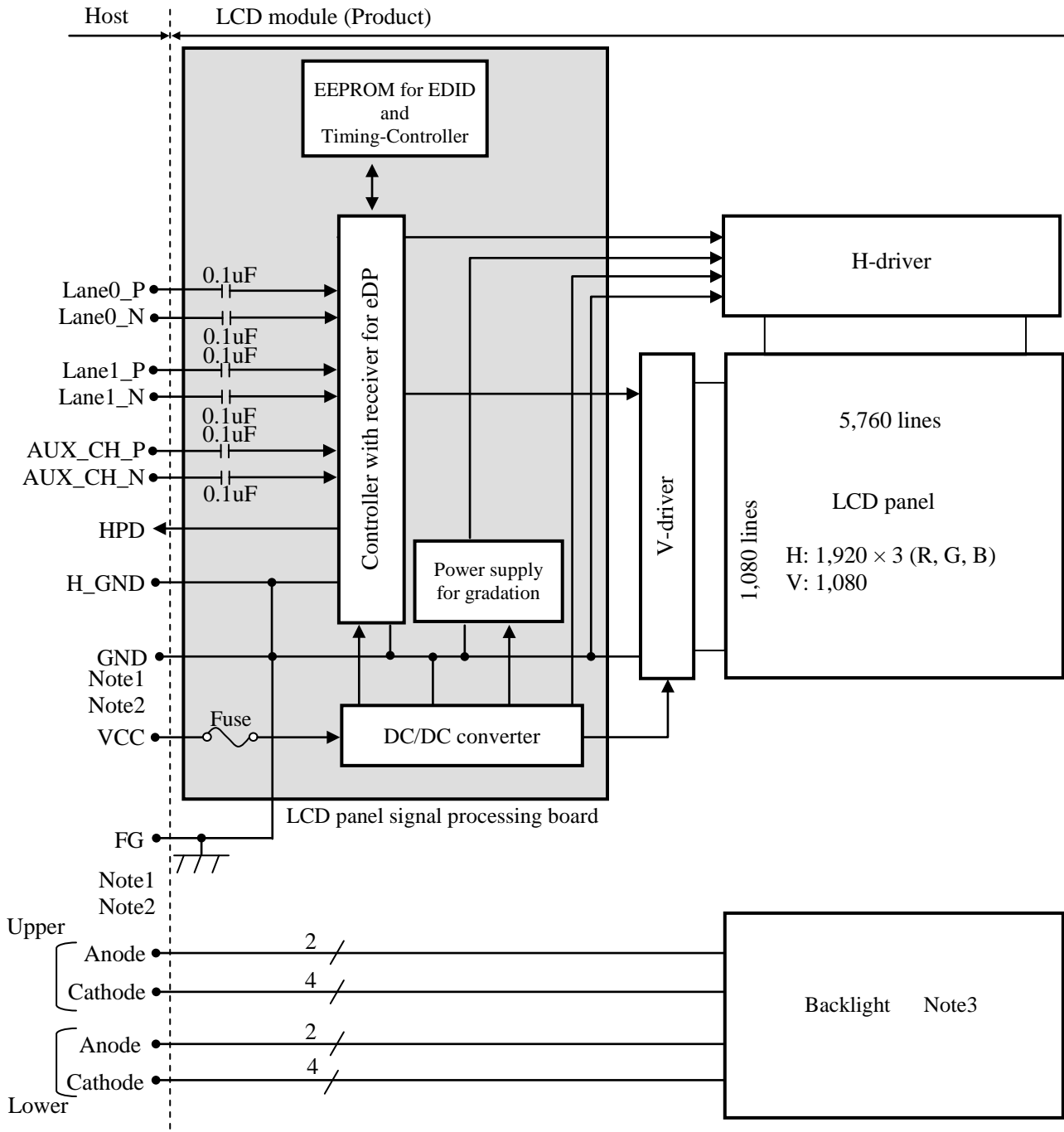

Note1: Relations between H_GND (High Speed Ground), GND (Signal ground) and FG (Frame ground) in the LCD module are as follows.

H_GND- GND	Connected
H_GND- FG	Connected
GND- FG	Connected

Note2: H_GND, GND and FG must be connected to customer equipment's ground, and it is recommended that these grounds to be connected together in customer equipment.

Note3: Backlight in detail

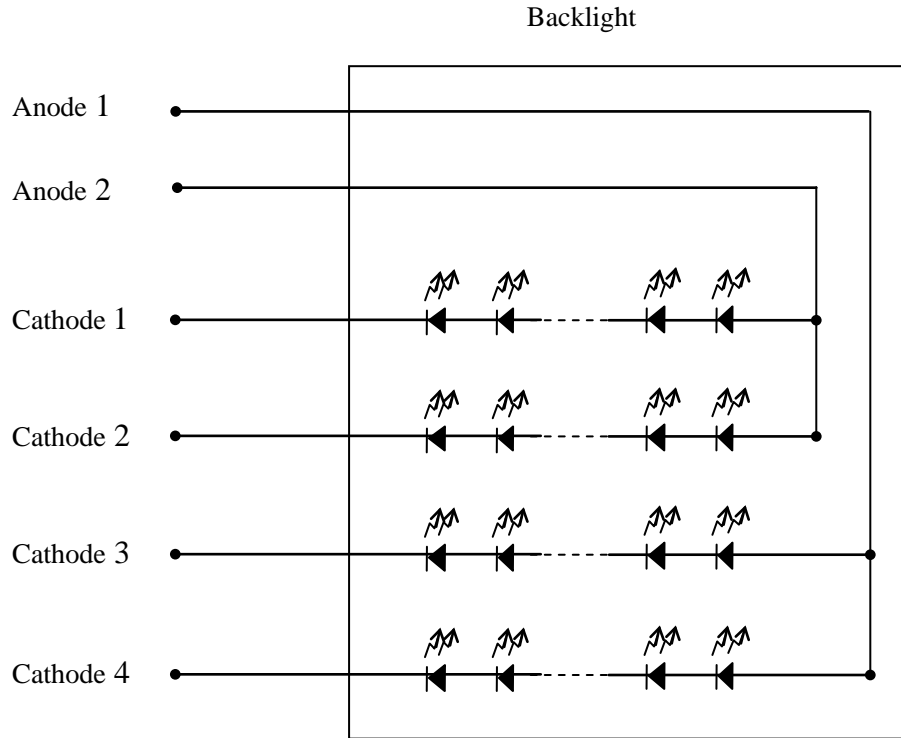

This figure is a common view of both upper and lower.

4. DETAILED SPECIFICATIONS
4.1 MECHANICAL SPECIFICATIONS

Parameter	Specification	Unit
Module size	363.8 ± 0.5 (W) × 215.9 ± 0.5 (H) × 15.7 ± 0.5 (D) Note1	mm
Display area	344.16 (H) × 193.59 (V) Note1	mm
Weight	1,050 (typ.), 1,150 (max.)	g

Note1: See "8. OUTLINE DRAWINGS".

4.2 ABSOLUTE MAXIMUM RATINGS

Parameter		Symbol	Rating	Unit	Remarks
Power supply voltage	LCD panel signal processing board	VCC	-0.3 to +4.0	V	Ta= 25°C
Input voltage for signals	Display signals	VD	-0.3 to +4.0	V	
Backlight	Forward current	IL	75	mA	per one circuit Ta = 25°C
Storage temperature		Tst	-40 to +85	°C	-
Operating temperature	Front surface	TopF	-30 to +85	°C	Note1
	Rear surface	TopR	-30 to +85	°C	Note2
Relative humidity Note3		RH	≤ 95	%	Ta ≤ 40°C
			≤ 85	%	40°C < Ta ≤ 50°C
			≤ 55	%	50°C < Ta ≤ 60°C
			≤ 36	%	60°C < Ta ≤ 70°C
			≤ 24	%	70°C < Ta ≤ 80°C
			≤ 20	%	80°C < Ta ≤ 85°C
Absolute humidity Note3		AH	≤ 70 Note4	g/m ³	Ta= 85°C

Note1: Measured at LCD panel surface (including self-heat)

Note2: Measured at LCD module's rear shield surface (including self-heat)

Note3: No condensation

Note4: Water amount at Ta= 85°C and RH= 20%

4.3 ELECTRICAL CHARACTERISTICS

4.3.1 LCD panel signal processing board

(Ta= 25°C, Note1)

Parameter	Symbol	min.	typ.	max.	Unit	Remarks
Power supply voltage	VCC	3.0	3.3	3.6	V	-
Power supply current	ICC	-	580 Note2	1,000 Note3	mA	at VCC= 3.3V
Permissible ripple voltage	VRPC	-	-	100	mVp-p	for VCC Note4, Note5, Note6

Note1: When designing of the power supply, take the measures for the prevention of surge voltage. ☆

Note2: Checkered flag pattern [by IEC 61747-6]

Note3: Pattern for maximum current

Note4: This product works even if the ripple voltage levels are over the permissible values, but there might be noise on the display image.

Note5: The permissible ripple voltage includes spike noise.

Note6: The load variation influence does not include.

4.3.2 Backlight

(Ta= 25°C, Note1, Note2, Note3)

Parameter	Symbol	min.	typ.	max.	Unit	Remarks
Forward current	IL	-	65	70	mA	-
Forward Voltage	VL	37.38	41.16	46.32	V	Ta= +25°C at IL= 65mA /One circuit
		35.72	-	-		Ta= +85°C at IL= 65mA /One circuit
		-	-	48.90		Ta= -30°C at IL= 65mA /One circuit
		-	-	49.40		Ta= -30°C at IL= 70mA /One circuit

Note1: Please drive the backlight with constant current.

Note2: The above specifications are for one LED circuit of the backlight.

Note3: The luminance uniformity may be changed depending on the current variation between 4 circuits. It is recommended that the current value difference among the circuits be less than 5%.

4.3.3 Fuse

Parameter	Fuse		Rating	Fusing current	Remarks
	Type	Supplier			
VCC	FCC16152AB	KAMAYA ELECTRIC CO., LTD	1.5A	3.0A 5seconds	Note1
			36V		

Note1: The power supply's rated current must be more than the fusing current. If it is less than the fusing current, the fuse may not blow in a short time, and then nasty smell, smoke and so on may occur.

4.4 POWER SUPPLY VOLTAGE SEQUENCE

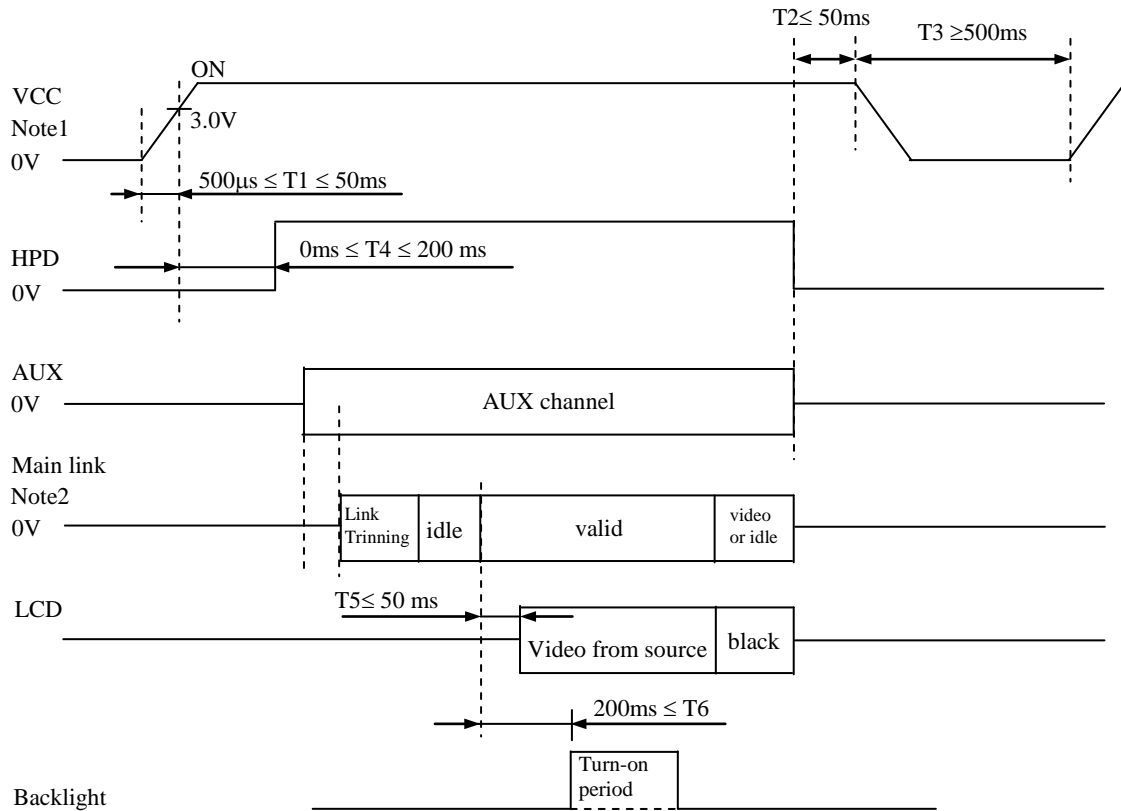

Note1: If there is a voltage variation (voltage drop) at the rising edge of VCC below 3.0V, there is a possibility that a product does not work due to a protection circuit.

Note2: Display signals (Lane0_P/N, Lane1_P/N) must be set to Low or High-impedance, except the VCC ON period (See above sequence diagram), in order to avoid the circuitry damage.

4.5 CONNECTIONS AND FUNCTIONS FOR INTERFACE PINS
4.5.1 LCD panel signal processing board

CN1 socket (LCD module side): 20455-040E (IPEX)
 Adaptable plug: 20453-240T-11 (IPEX, Plug Set)
 20454-240T (IPEX, HOUSING) or equivalent

Pin	Signal Name	Description	Remarks
1	N.C.	Keep this pin Open.	-
2	N.C.		
3	N.C.		
4	N.C.		
5	N.C.		
6	N.C.		
7	N.C.		
8	H_GND	High Speed Ground	Note1
9	Lane1_N	Complement Signal Link Lane 1	-
10	Lane1_P	True Signal Link Lane 1	-
11	H_GND	High Speed Ground	Note1
12	Lane0_N	Complement Signal Link Lane 0	-
13	Lane0_P	True Signal Link Lane 0	-
14	H_GND	High Speed Ground	Note1
15	AUX_CH_P	True Signal Auxiliary Channel	-
16	AUX_CH_N	Complement Signal Auxiliary Channel	-
17	H_GND	High Speed Ground	Note1
18	VCC	Power supply for LCD panel signal processing board	Note1
19	VCC		
20	VCC		
21	VCC		
22	RSVD	Keep this pin Open.	-
23	GND	Ground	Note1
24	GND		
25	GND		
26	GND		
27	HPD	HPD Signal Pin	-
28	N.C.	Keep this pin Open.	-
29	N.C.		
30	N.C.		
31	N.C.		
32	N.C.		
33	N.C.		
34	N.C.		
35	N.C.		
36	N.C.		
37	N.C.		
38	N.C.		
39	N.C.		
40	N.C.		

Note1: All H_GND, GND and VCC terminals should be used without any non-connected lines.

4.5.2 Backlight

CN2 socket (LCD module side): BM06B-SHJS-TB (HF) (J.S.T. Mfg. Co., Ltd.)
 Adaptable plug: SHJP-06V-S (HF) (J.S.T. Mfg. Co., Ltd.)

Pin No.	Symbol	Signal	Remarks
1	A1	Anode 1	-
2	A2	Anode 2	-
3	K1	Cathode 1	-
4	K2	Cathode 2	-
5	K3	Cathode 3	-
6	K4	Cathode 4	-

CN3 socket (LCD module side): BM06B-SHJS-TB (HF) (J.S.T. Mfg. Co., Ltd.)
 Adaptable plug: SHJP-06V-S (HF) (J.S.T. Mfg. Co., Ltd.)

Pin No.	Symbol	Signal	Remarks
1	K4	Cathode 4	-
2	K3	Cathode 3	-
3	K2	Cathode 2	-
4	K1	Cathode 1	-
5	A2	Anode 2	-
6	A1	Anode 1	-

4.5.3 Positions of socket

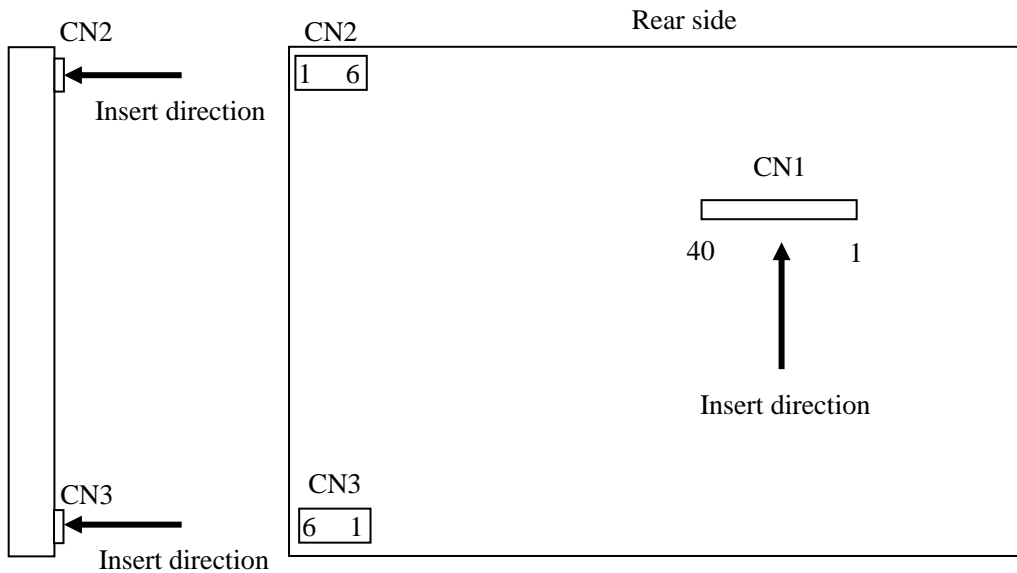

4.6 DISPLAY COLORS AND INPUT DATA SIGNALS

This product can display equivalent of 16,777,216 colors with 256 gray scales.
 Also the relation between display colors and input data signals is as follows.

Display colors		Input color data																							
		Red								Green								Blue							
		R7	R6	R5	R4	R3	R2	R1	R0	G7	G6	G5	G4	G3	G2	G1	G0	B7	B6	B5	B4	B3	B2	B1	B0
Basic Colors	Black	0	0	0	0	0	0	0	0	0	0	0	0	0	0	0	0	0	0	0	0	0	0	0	0
	Blue	0	0	0	0	0	0	0	0	0	0	0	0	0	0	0	0	1	1	1	1	1	1	1	1
	Red	1	1	1	1	1	1	1	1	0	0	0	0	0	0	0	0	0	0	0	0	0	0	0	0
	Magenta	1	1	1	1	1	1	1	1	0	0	0	0	0	0	0	0	1	1	1	1	1	1	1	1
	Green	0	0	0	0	0	0	0	0	1	1	1	1	1	1	1	1	0	0	0	0	0	0	0	0
	Cyan	0	0	0	0	0	0	0	0	1	1	1	1	1	1	1	1	1	1	1	1	1	1	1	1
	Yellow	1	1	1	1	1	1	1	1	1	1	1	1	1	1	1	1	0	0	0	0	0	0	0	0
	White	1	1	1	1	1	1	1	1	1	1	1	1	1	1	1	1	1	1	1	1	1	1	1	1
Red gray scale	Black	0	0	0	0	0	0	0	0	0	0	0	0	0	0	0	0	0	0	0	0	0	0	0	0
		0	0	0	0	0	0	0	1	0	0	0	0	0	0	0	0	0	0	0	0	0	0	0	0
	dark	0	0	0	0	0	0	1	0	0	0	0	0	0	0	0	0	0	0	0	0	0	0	0	0
	↑				:	:							:	:						:	:				
	↓				:	:							:	:						:	:				
	bright	1	1	1	1	1	1	0	1	0	0	0	0	0	0	0	0	0	0	0	0	0	0	0	0
Red	1	1	1	1	1	1	1	0	0	0	0	0	0	0	0	0	0	0	0	0	0	0	0	0	
Red	1	1	1	1	1	1	1	1	0	0	0	0	0	0	0	0	0	0	0	0	0	0	0	0	
Green gray scale	Black	0	0	0	0	0	0	0	0	0	0	0	0	0	0	0	0	0	0	0	0	0	0	0	0
		0	0	0	0	0	0	0	0	0	0	0	0	0	0	0	1	0	0	0	0	0	0	0	0
	dark	0	0	0	0	0	0	0	0	0	0	0	0	0	0	1	0	0	0	0	0	0	0	0	0
	↑				:	:							:	:						:	:				
	↓				:	:							:	:						:	:				
	bright	0	0	0	0	0	0	0	0	1	1	1	1	1	1	0	1	0	0	0	0	0	0	0	0
Green	0	0	0	0	0	0	0	0	1	1	1	1	1	1	1	0	0	0	0	0	0	0	0	0	
Green	0	0	0	0	0	0	0	0	1	1	1	1	1	1	1	1	0	0	0	0	0	0	0	0	
Blue gray scale	Black	0	0	0	0	0	0	0	0	0	0	0	0	0	0	0	0	0	0	0	0	0	0	0	0
		0	0	0	0	0	0	0	0	0	0	0	0	0	0	0	0	0	0	0	0	0	0	0	1
	dark	0	0	0	0	0	0	0	0	0	0	0	0	0	0	0	0	0	0	0	0	0	0	1	0
	↑				:	:							:	:						:	:				
	↓				:	:							:	:						:	:				
	bright	0	0	0	0	0	0	0	0	0	0	0	0	0	0	0	0	1	1	1	1	1	1	0	1
Blue	0	0	0	0	0	0	0	0	0	0	0	0	0	0	0	0	1	1	1	1	1	1	1	0	
Blue	0	0	0	0	0	0	0	0	0	0	0	0	0	0	0	0	1	1	1	1	1	1	1	1	

4.7 INPUT DATA SIGNALS AND DISPLAY POSITIONS

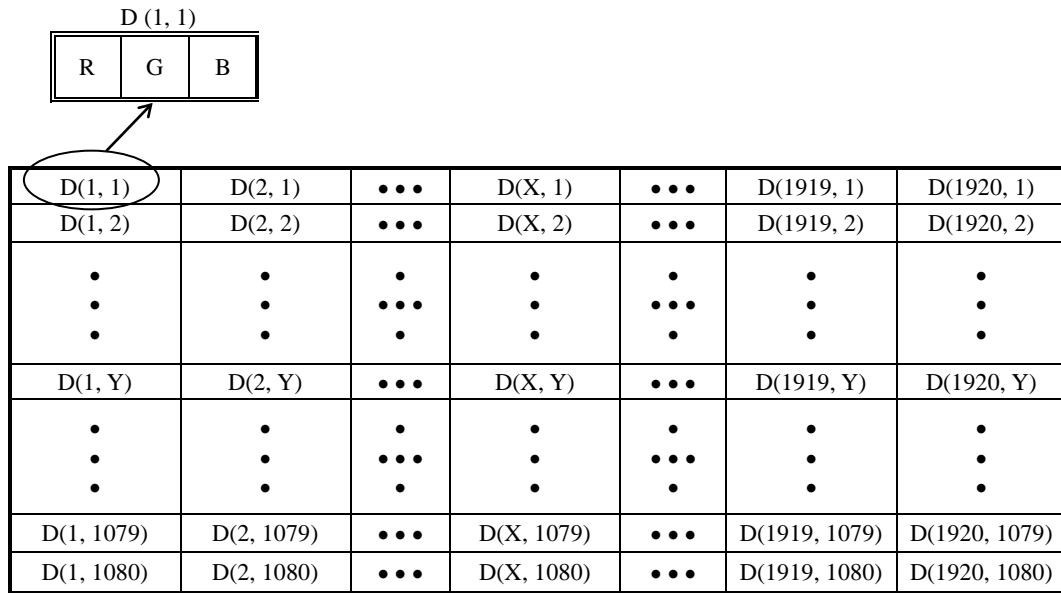

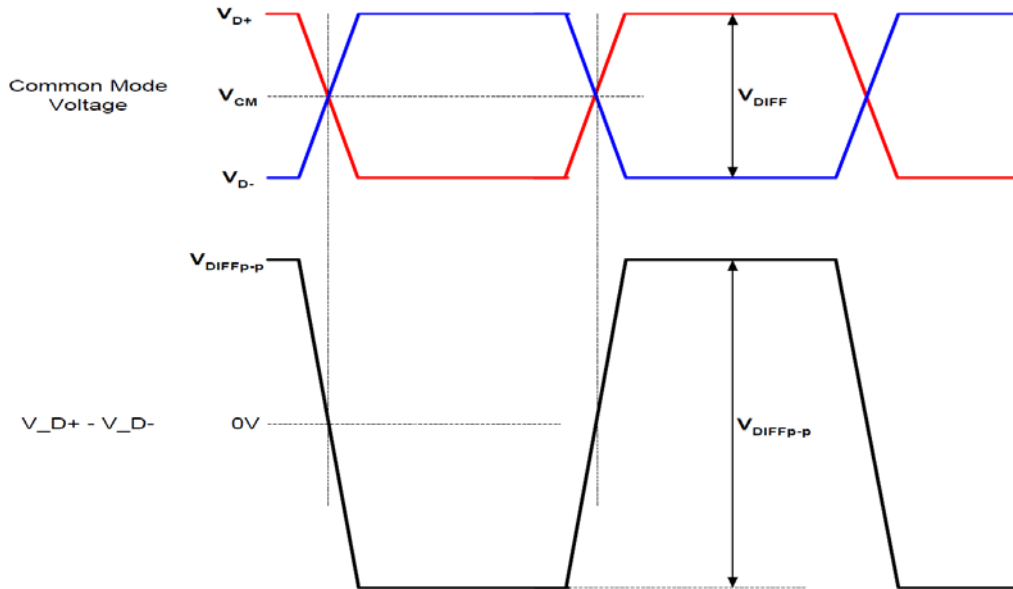
4.8 eDP SIGNAL TIMING SPECIFICATIONS
4.8.1 Display Port main link signal

Parameter	Symbol	min.	typ.	max.	Unit	Remarks
Differential peak-to-peak Input voltage	VDIFFp-p	100	-	1,320	mV	-
Rx input DC common Mode Voltage	VCM	-	0	-	V	-
Jitter tracking bandwidth	-	10	-	-	MHz	-
Link clock down spreading	-	-	0.5	-	%	-

4.8.2 Display Port HPD signal

Description	Symbol	min.	typ.	max.	Unit	Remarks
Hot Plug detect	HPD	2.0	-	2.5	V	I/O type: LVTTTL

4.8.3 Display port AUX signal

Description	Symbol	min.	typ.	max.	Unit	Remarks
AUX differential peak-to-peak voltage When driving	-	0.4	-	1	V	-
AUX differential peak-to-peak voltage When receiving	-	0.25	-	1.36	V	-
AUX common-mode voltage When transmitting	-	-	0.15	-	V	-
AUX common-mode voltage When receiving	-	-	GND	-	V	-
AUX differential termination resistance	-	80	100	120	Ω	-
Unit interval	-	0.4	0.5	0.6	μ s	-
Cycle-to-cycle jitter time	-	-	-	0.04	UI	-

4.9 INPUT SIGNAL TIMINGS

4.9.1 Outline of input signal timings

- Horizontal signal

Note1

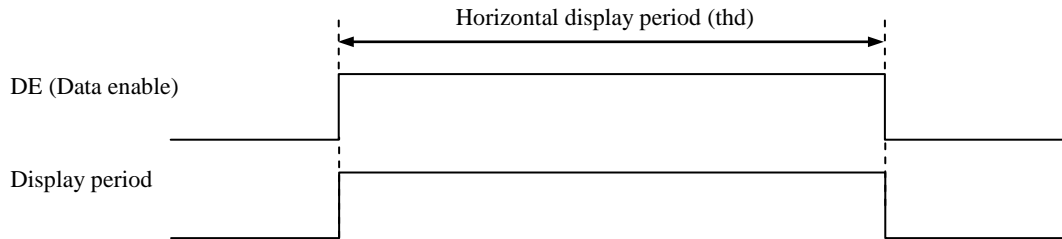

- Vertical signal

Note1

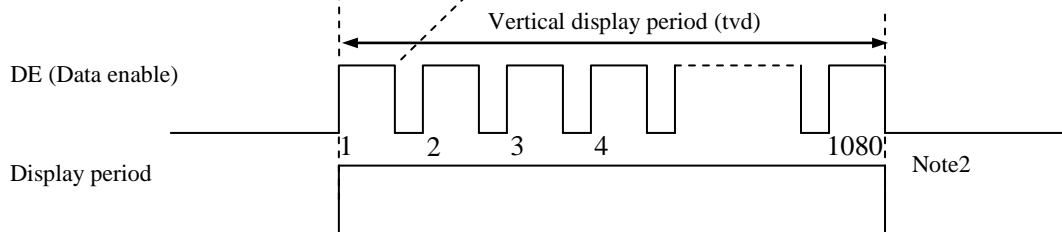

Note1: This diagram indicates virtual signal for set up to timing.

Note2: See "4.9.3 Input signal timing chart" for the pulse number.

4.9.2 Timing characteristics

(Note1)

Parameter		Symbol	min.	typ.	max.	Unit	Remarks	
CLK	Frequency	1/tc	111.0	138.5	166.5	MHz	7.22ns (typ.)	
	Duty ratio	-	-			-	-	
	Rise time, Fall time	-	-			ns	-	
DE	Horizontal	Cycle	th	-	15.02	-	μ s	66.59 kHz (typ.)
		Display period	thd	1,920			CLK	
	Vertical (One frame)	Cycle	tv	-	16.70	-	ms	59.88Hz (typ.)
		Display period	tvd	1,080			H	

Note1: Definition of parameters is as follows.
 $t_c = 1CLK$, $t_h = 1H$

4.9.3 Input signal timing chart

Horizontal timing

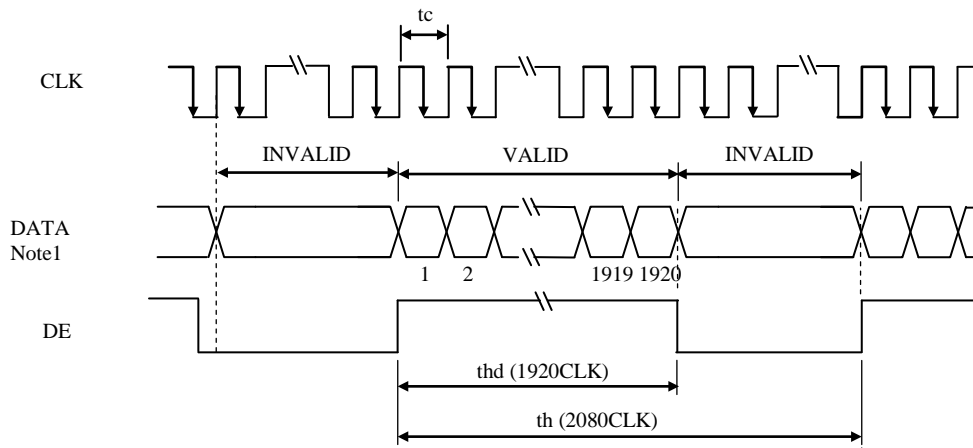

Vertical timing

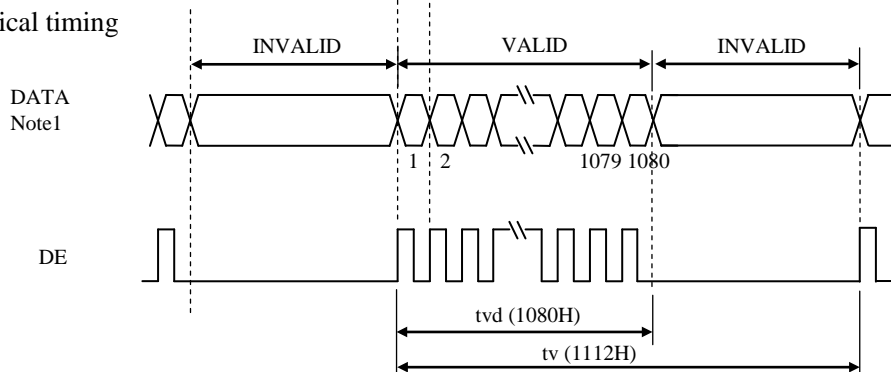

Note1: DATA=R0-R7, G0-G7, B0-B7

4.10 OPTICS

4.10.1 Optical characteristics

(Note1, Note2)

Parameter	Condition	Symbol	min.	typ.	max.	Unit	Measuring instrument	Remarks	
Luminance	White at center $\theta R=0^\circ, \theta L=0^\circ, \theta U=0^\circ, \theta D=0^\circ$	L	1,200	1,500	-	cd/m ²	BM-5A or equivalent	-	
Contrast ratio	White/Black at center $\theta R=0^\circ, \theta L=0^\circ, \theta U=0^\circ, \theta D=0^\circ$	CR	500	750	-	-	BM-5A or equivalent	Note3	
Luminance uniformity	White $\theta R=0^\circ, \theta L=0^\circ, \theta U=0^\circ, \theta D=0^\circ$	LU	-	1.25	1.4	-	BM-5A or equivalent	Note4	
Chromaticity	White	x coordinate	W _x	0.263	0.313	0.363	-	SR-3 or equivalent	Note5
		y coordinate	W _y	0.279	0.329	0.379	-		
	Red	x coordinate	R _x	-	0.565	-	-		
		y coordinate	R _y	-	0.345	-	-		
	Green	x coordinate	G _x	-	0.340	-	-		
		y coordinate	G _y	-	0.530	-	-		
Blue	x coordinate	B _x	-	0.150	-	-			
	y coordinate	B _y	-	0.105	-	-			
Color gamut	$\theta R=0^\circ, \theta L=0^\circ, \theta U=0^\circ, \theta D=0^\circ$ at center, against NTSC color space	C	35	40	-	%			
Response time	Black to White	T _{on}	-	15	20	ms	BM-5A or equivalent	Note6	
	White to Black	T _{off}	-	15	20	ms		Note7	
Viewing angle	Right	$\theta U=0^\circ, \theta D=0^\circ, CR \geq 10$	θR	70	88	-	EZ Contrast	Note8	
	Left	$\theta U=0^\circ, \theta D=0^\circ, CR \geq 10$	θL	70	88	-			
	Up	$\theta R=0^\circ, \theta L=0^\circ, CR \geq 10$	θU	70	88	-			
	Down	$\theta R=0^\circ, \theta L=0^\circ, CR \geq 10$	θD	70	88	-			

Note1: These are initial characteristics.

Note2: Measurement conditions are as follows.

T_a= 25°C, VCC= 3.3V, I_L= 65mA/One Circuit, Display mode: FHD,
Horizontal cycle= 1/66.59kHz, Vertical cycle= 1/59.88Hz

Optical characteristics are measured at luminance saturation 20minutes after the product works, in the dark room. Also measurement methods are as follows.

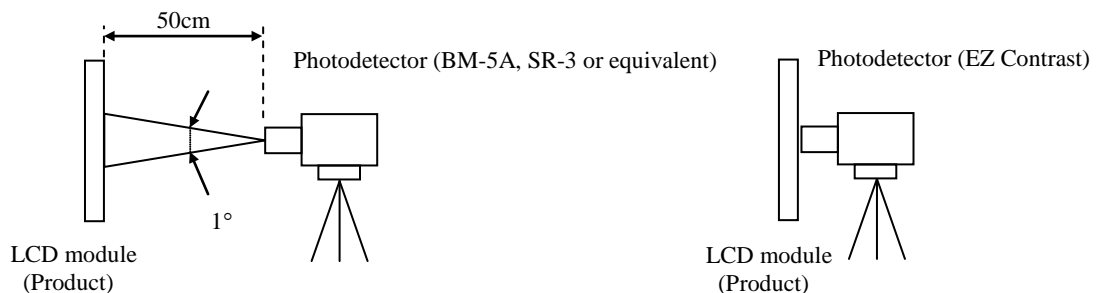

Note3: See "4.10.2 Definition of contrast ratio".

Note4: See "4.10.3 Definition of luminance uniformity".

Note5: These coordinates are found on CIE 1931 chromaticity diagram.

Note6: Product surface temperature: TopF= 40°C

Note7: See "4.10.4 Definition of response times".

Note8: See "4.10.5 Definition of viewing angles".

4.10.2 Definition of contrast ratio

The contrast ratio is calculated by using the following formula.

$$\text{Contrast ratio (CR)} = \frac{\text{Luminance of white screen}}{\text{Luminance of black screen}}$$

4.10.3 Definition of luminance uniformity

The luminance uniformity is calculated by using following formula.

$$\text{Luminance uniformity (LU)} = \frac{\text{Maximum luminance from ① to ⑤}}{\text{Minimum luminance from ① to ⑤}}$$

The luminance is measured at near the 5 points shown below.

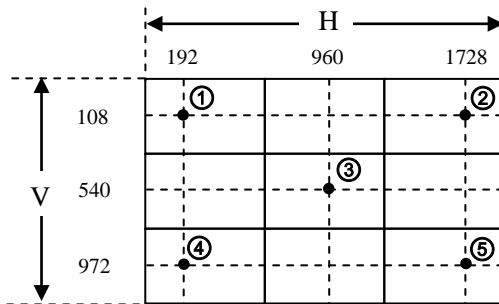

4.10.4 Definition of response times

Response time is measured at the time when the luminance changes from "black" to "white", or "white" to "black" on the same screen point, by photo-detector. Ton is the time when the luminance changes from 10% up to 90%. Also Toff is the time when the luminance changes from 90% down to 10% (See the following diagram.).

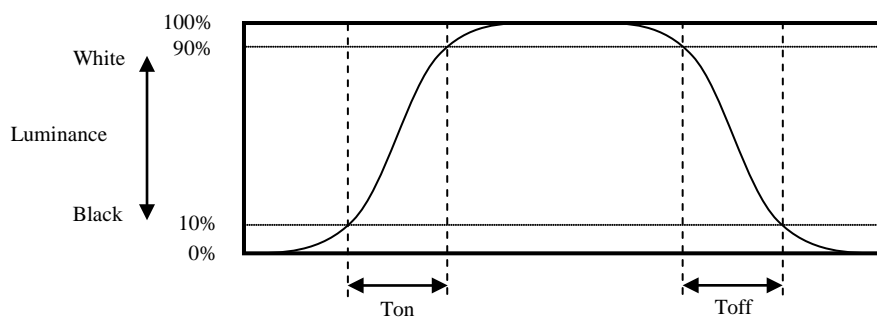

4.10.5 Definition of viewing angles

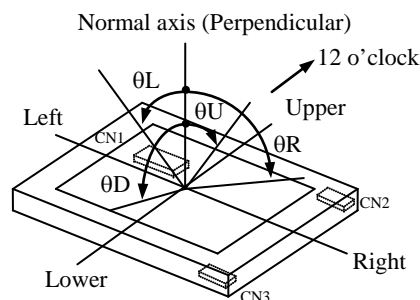

5. ESTIMATED LUMINANCE LIFETIME

The luminance lifetime is the time from initial luminance to half-luminance.

This lifetime is the estimated value, and is not guarantee value.

Condition		Estimated luminance lifetime (Life time expectancy) Note1, Note2, Note3	Unit
LED elementary substance	25°C (Ambient temperature of the product) Continuous operation, IL= 65mA/One circuit	50,000	h
	85°C (Temperature of LCD panel surface and rear shield surface) Continuous operation, IL= 65mA/One circuit	30,000	

Note1: Life time expectancy is mean time to half-luminance.

Note2: Estimated luminance lifetime is not the value for LCD module but the value for LED elementary substance.

Note3: By ambient temperature, the lifetime changes particularly. Especially, in case the product works under high temperature environment, the lifetime becomes short.

6. RELIABILITY TESTS

Test item	Condition	Judgment	Note1
High temperature and humidity (Operation)	① $+60 \pm 2^{\circ}\text{C}$, RH= 90%, 240hours ② Display data is white.	No display malfunctions	
High temperature (Operation)	① $+85 \pm 3^{\circ}\text{C}$, 240hours ② Display data is white.		
Heat cycle (Operation)	① $-30 \pm 3^{\circ}\text{C}$...1hour $+85 \pm 3^{\circ}\text{C}$...1hour ② 50cycles, 4 hours/cycle ③ Display data is white.		
Thermal shock (Non operation)	① $-40 \pm 3^{\circ}\text{C}$...30minutes $+85 \pm 3^{\circ}\text{C}$...30minutes ② 100cycles, 1hour/cycle ③ Temperature transition time is within 5 minutes.		
ESD (Operation)	① 150pF, 150Ω, $\pm 10\text{kV}$ ② 9 places on a panel surface Note2 ③ 10 times each place at 1 sec interval		
Dust (Operation)	① Sample dust: No. 15 (by JIS-Z8901) ② 15 seconds stir ③ 8 times repeat at 1 hour interval		
Vibration (Non operation)	① 5 to 100Hz, 11.76m/s^2 ② 1 minute/cycle ③ X, Y, Z directions ④ 50 times each direction		
Mechanical shock (Non operation)	① 294m/s^2 , 11ms ② $\pm\text{X}$, $\pm\text{Y}$, $\pm\text{Z}$ directions ③ 3 times each direction		

Note1: Display and appearance are checked under environmental conditions equivalent to the inspection conditions of defect criteria.

Note2: See the following figure for discharge points.

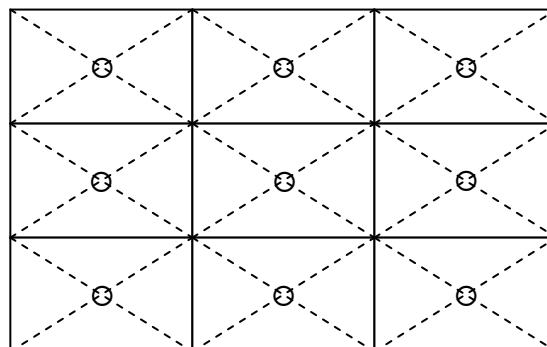

7. PRECAUTIONS

7.1 MEANING OF CAUTION SIGNS

The following caution signs have very important meaning. **Be sure to read "10.2 CAUTIONS" and "10.3 ATTENTIONS"!**

	This sign has the meaning that a customer will be injured or the product will sustain damage if the customer practices wrong operations.
---	--

	This sign has the meaning that a customer will be injured if the customer practices wrong operations.
---	---

7.2 CAUTIONS

	<p>* Do not shock and press the LCD panel and the backlight! There is a danger of breaking, because they are made of glass. (Shock: Equal to or no greater than 294m/s² and equal to or no greater than 11ms, Pressure: Equal to or no greater than 19.6 N (φ16mm jig))</p>
---	---

7.3 ATTENTIONS 

7.3.1 Handling of the product

- ① Take hold of both ends without touching the circuit board when the product (LCD module) is picked up from inner packing box to avoid broken down or misadjustment, because of stress to mounting parts on the circuit board.
- ② When the product is put on the table temporarily, display surface must be placed downward.
- ③ When handling the product, take the measures of electrostatic discharge with such as earth band, ionic shower and so on, because the product may be damaged by electrostatic.
- ④ The torque for product mounting screws must never exceed 0.34N·m. Higher torque might result in distortion of the bezel. And the length of product mounting screws must be ≤ 2.8mm.
- ⑤ The product must be installed using mounting holes without undue stress such as bends or twist (See outline drawings). And do not add undue stress to any portion (such as bezel flat area). Bends or twist described above and undue stress to any portion may cause display mura.
Recommended installing method: Ideal plane "A" is defined by one mounting hole (datum point) and other mounting holes. The ideal plane "A" should be the same plane within ±0.3 mm.

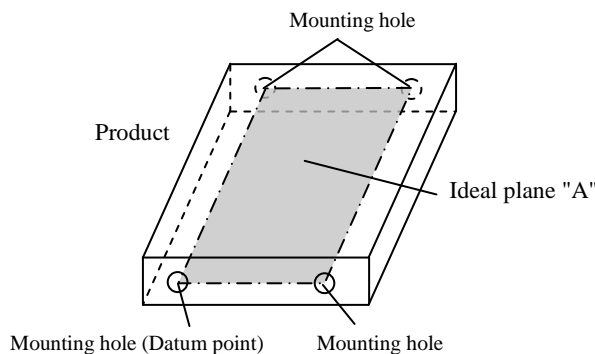

- ⑥ Do not press or rub on the sensitive product surface. When cleaning the panel surface, wipe it with a soft dry cloth.
- ⑦ Do not push or pull the interface connectors while the product is working. When handling the product, use of an original protection sheet on the product surface (polarizer) is recommended for protection of product surface. Adhesive type protection sheet may change color or characteristics of the polarizer.
- ⑧ Usually liquid crystals don't leak through the breakage of glasses because of the surface tension of thin layer and the construction of LCD panel. But, if you contact with liquid crystal by any chance, please wash it away with soap and water.

7.3.2 Environment

- ① Do not operate or store in high temperature, high humidity, dewdrop atmosphere or corrosive gases. Keep the product in packing box with antistatic pouch in room temperature to avoid dusts and sunlight, when storing the product.
- ② In order to prevent dew condensation occurred by temperature difference, the product packing box must be opened after enough time being left under the environment of an unpacking room. Evaluate the storage time sufficiently because dew condensation is affected by the environmental temperature and humidity. (Recommended leaving time: 6 hours or more with the original packing state after a customer receives the package)
- ③ Do not operate in high magnetic field. If not, circuit boards may be broken.
- ④ This product is not designed as radiation hardened.

7.3.3 Characteristics

The following items are neither defects nor failures.

- ① Characteristics of the LCD (such as response time, luminance, color uniformity and so on) may be changed depending on ambient temperature. If the product is stored under condition of low temperature for a long time, it may cause display mura. In this case, the product should be operated after enough time being left under condition of operating temperature.
- ② Display mura, flickering, vertical streams or tiny spots may be observed depending on display patterns.
- ③ Do not display the fixed pattern for a long time because it may cause image sticking. Use a screen saver, if the fixed pattern is displayed on the screen.
- ④ The display color may be changed depending on viewing angle because of the use of condenser sheet in the backlight.
- ⑤ Optical characteristics may be changed depending on input signal timings.

7.3.4 Others

- ① All GND, H_GND and VCC terminals should be used without any non-connected lines.
- ② Do not disassemble a product or adjust variable resistors.
- ③ Pack the product with the original shipping package, in order to avoid any damages during transportation, when returning the product to TMJ.
- ④ The information of China RoHS (II) six hazardous substances or elements in this product is as follows.

China RoHS (II) six hazardous substances or elements					
Lead (Pb)	Mercury (Hg)	Cadmium (Cd)	Hexavalent Chromium (Cr VI)	Polybrominated Biphenyls (PBB)	Polybrominated Biphenyl Ethers (PBDE)
×	○	○	○	○	○

Note1: ○: This indicates that the poisonous or harmful material in all the homogeneous materials for this part is equal or below the limitation level of GB/T26572-2011 standard regulation.

×: This indicates that the poisonous or harmful material in all the homogeneous materials for this part is above the limitation level of S GB/T26572-2011 standard regulation.

8. OUTLINE DRAWINGS

8.1 FRONT VIEW

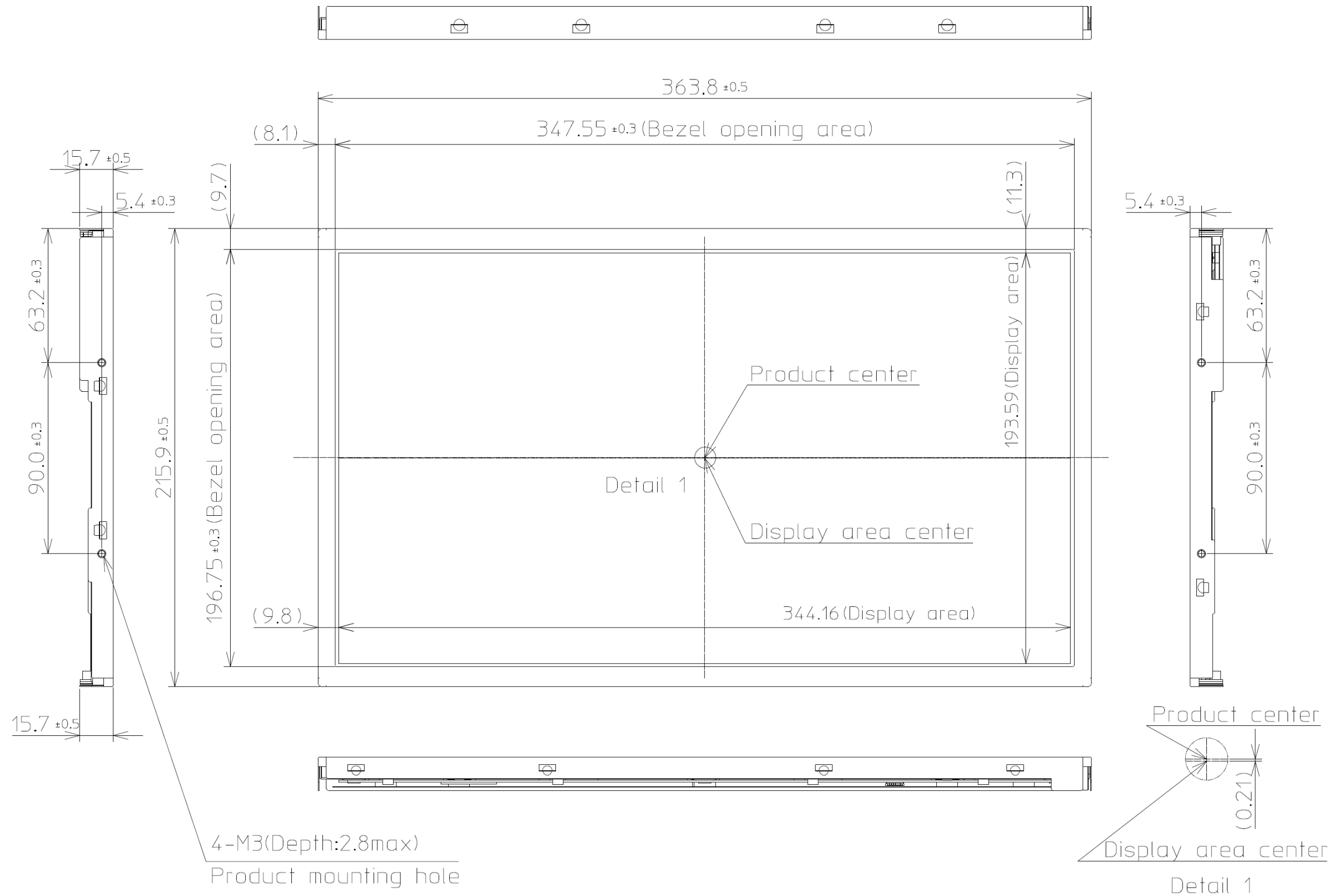

Unit: mm

Note1: The values in parentheses are for reference.

Note2: The torque for product mounting screws must never exceed 0.34N·m. And the length of product mounting screws must be ≤ 2.8 mm.

8.2 REAR VIEW

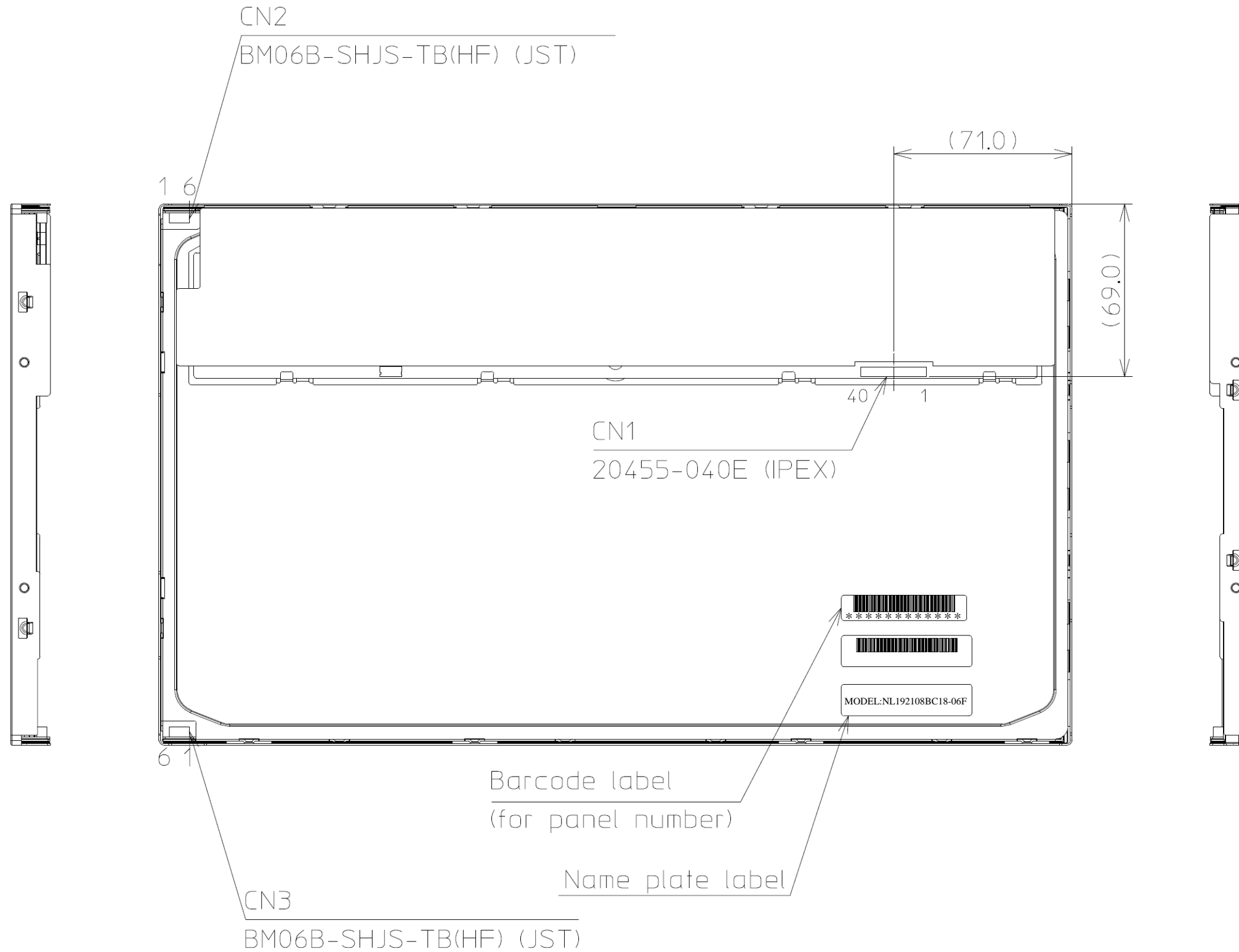

Note1: The values in parentheses are for reference.

Unit: mm