

**MODEL NO : P0840XGF1MA00****SPEC VERSION : 1.3****ISSUED DATE: 2021-01-28**

- Preliminary Specification  
 Final Product Specification

Customer : \_\_\_\_\_

Approved by	Notes Date

TIANMA Confirmed :

Prepared by	Checked by	Approved by
Bin.Wang	Longping.Deng	Jinquan.Liu

This technical specification is subjected to change without notice.

## Table of Contents

Table of Contents .....	2
Record of Revision .....	3
1 General Specifications .....	4
2 Input/Output Terminals .....	5
3 Absolute Maximum Ratings .....	6
4 Electrical Characteristics .....	7
5 Timing Chart .....	10
6 Optical Characteristics .....	13
7 Environmental / Reliability Test .....	16
8 Mechanical Drawing .....	17
9 Packing Drawing .....	18
10 Precautions for Use of LCD Modules .....	19

TIANMA CONFIDENTIAL



## 1 General Specifications

	Feature	Spec
<b>Display Spec.</b>	Size(inch)	8.4
	Resolution	1024x768
	Technology Type	a-Si
	Pixel Configuration	R.G.B. Vertical Stripe
	Pixel pitch(mm)	0.1665 x 0.1665
	Display Mode	SFT, Normally Black
	Surface Treatment	AG
	Viewing Direction	All Direction
<b>Mechanical Characteristics</b>	LCM (W x H x D) (mm)	199.5x149x9.7
	Active Area(mm)	170.496*127.872
	With /Without TP	Without
	Matching Connection	CN1 : FI-SEB20P-HFE CN2: SM06B-SHLS-TF(LF)(SN)(JST)
	LED Numbers	21 LEDS
	Weight (g)	303
<b>Electrical Characteristics</b>	Interface	LVDS
	Color Depth	16.7 Million color/262 Kilo color
	Driver IC	NT51625TTH*2+NT52602TTH*1

Note 1: Requirements on Environmental Protection: Q/S0002.

Note 2: LCM weight tolerance:  $\pm 5\%$ .

## 2 Input/Output Terminals

### 2.1 LCD Interface PINs

Matching Connector: FI-SEB20P-HFE

Pin No.	Symbol	I/O	Function	Remark
1	VCC	P	3.3V power supply	
2	VCC	P	3.3V power supply	
3	GND	P	Ground	Note2
4	GND	P	Ground	Note2
5	Link0-	I	Negative LVDS differential data input	
6	Link0+	I	Positive LVDS differential data input	
7	GND	P	Ground	Note2
8	Link1-	I	Negative LVDS differential data input	
9	Link1+	I	Positive LVDS differential data input	
10	GND	P	Ground	Note2
11	Link2-	I	Negative LVDS differential data input	
12	Link2+	I	Positive LVDS differential data input	
13	GND	P	Ground	Note2
14	CLKIN-	I	Negative LVDS differential data input	
15	CLKIN+	I	Positive LVDS differential data input	
16	GND	P	Ground	Note2
17	Link3-	I	Negative LVDS differential data input	Note3
18	Link3+	I	Positive LVDS differential data input	Note3
19	MODE	I	6-bit / 8-bit input select for LVDS interface. High : 8bit Low : 6bit.	
20	SC	I	Reverse Scan control Low : Normal scan High or Open : Reverse scan	Note4

Note1: I---Input, O---Output, P--- Power/Ground

Note2: All of the GND Pins should be connected to the system ground.

Note3: Please set to GND if pin is NOT in use.

Note4: The function of the SC. The figure below is a front view.

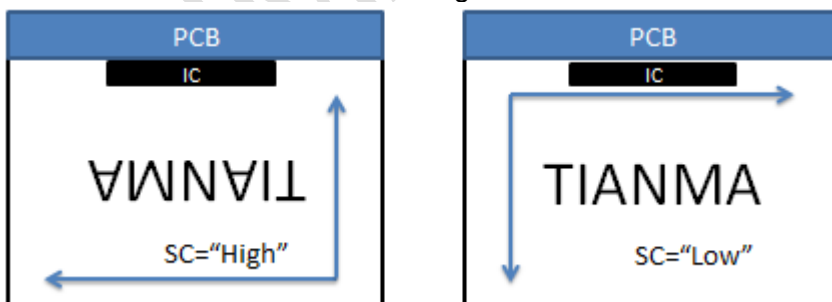

Figure2.1 Scanning diagram

## 2.2 CN2 pin assignment (Backlight interface)

Matching Connector type: SM06B-SHLS-TF (LF)(SN) (JST)

Pin	Symbol	I/O	Description	Remark
1	NC	-	This pin should be open.	-
2	NC	-	This pin should be open.	-
3	LED C1	P	LED cathode 1	Note1
4	LED A1	P	LED anode 1	Note2
5	LED A2	P	LED anode 2	Note2
6	LED C2	P	LED cathode 2	Note1

Note1: LED C1, LED C2 connected together on the PCB and then connected with K of the backlight..

Note2: LED A1, LED A2 connected together on the PCB and then connected with A of the backlight.

## 3 Absolute Maximum Ratings

GND=0V

Item	Symbol	MIN	MAX	Unit	Remark
Input voltage	$V_{IN}$	-0.3	5	V	Note1
Operating Temperature	Top	-30	80	°C	-
Storage Temperature	Tst	-40	90	°C	-
Relative Humidity Note2	RH	--	≤95	%	$T_a \leq 40^\circ\text{C}$
		--	≤85	%	$40^\circ\text{C} < T_a \leq 50^\circ\text{C}$
		--	≤55	%	$50^\circ\text{C} < T_a \leq 60^\circ\text{C}$
		--	≤36	%	$60^\circ\text{C} < T_a \leq 70^\circ\text{C}$
		--	≤24	%	$70^\circ\text{C} < T_a \leq 80^\circ\text{C}$
Absolute Humidity	AH	--	≤70	$\text{g/m}^3$	$T_a > 70^\circ\text{C}$

**Table 3 Absolute Maximum Ratings**

Note1: Input voltage include MODE,SC, Link0-/+, Link1-/+, Link2-/+, Link3-/+,VCC.

 Note2:  $T_a$  means the ambient temperature.

 It is necessary to limit the relative humidity to the specified temperature range.  
 Condensation on the module is not allowed.

## 4 Electrical Characteristics

### 4.1 Driving TFT LCD Panel

 $VCC=3.3V, GND=0V, Ta = 25^{\circ}C$ 

Item	Symbol	MIN	TYP	MAX	Unit	Remark
Power supply voltage	VCC	3.2	3.3	3.4	V	Note1
Power Ground	GND	-	0	-	V	
Input High Voltage	$V_{IH}$	$0.7 \times VCC$		VCC	V	Note1
Input Low Voltage	$V_{IL}$	GND		$0.3 \times VCC$	V	
LVDS differential input high threshold voltage	RxVTH	-	-	+200	mV	Note2
LVDS differential input low threshold voltage	RxVTL	-200	-	-		
Differential input voltage	$ V_{ID} $	200	-	600	mV	
Differential input common mode voltage	RxVCM	1.0	1.2	$1.7 - \frac{ V_{ID} }{2}$	V	
Current of VCC Power supply	IVCC	-	310	-	mA	Note3
Power consumption	P	-	1023	-	mW	
Inrush current of VCC	Irush	-	TBD	TBD	A	Note4

Table 4.1 LCD electrical characteristics

Note1: Including MODE,SC.

Note2: Refers to the LVDS waveform as shown below:

Note3: Test in white pattern

Note4: VCC rising time >1ms.

#### Single-end Signal

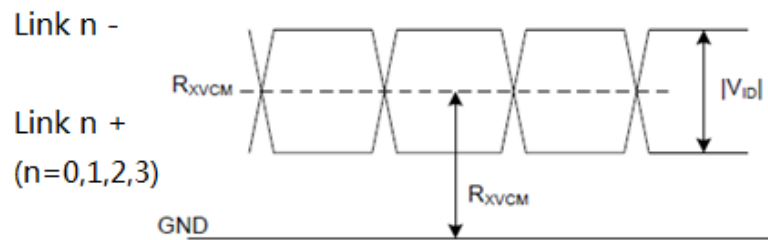

#### Differential Signal

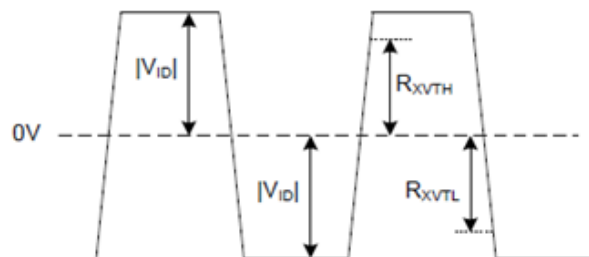

Figure4.1 LVDS DC Diagram

### 4.2 Backlight Unit Driving Condition

GND=0V, Ta = 25°C

Parameter	Symbol	min.	typ.	max.	Unit	Remarks
Power supply voltage	VF	-	22.4	-	V	Ta=25°C
Power supply current	IF	-	300	-	mA	
Power consumption of Backlight	P	-	6720	-	mW	
LED Life time	LT	-	100000	-	Hrs	

Note 1: The figure below shows the connection of backlight LED.

Note 2: K1, K2, K3 connected together on the PCB.

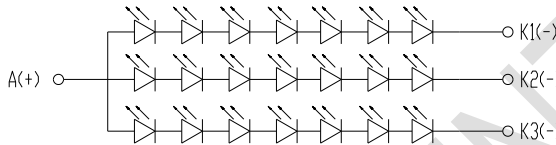

Figure4.2 LED connection of backlight

### 4.3 BLOCK DIAGRAM

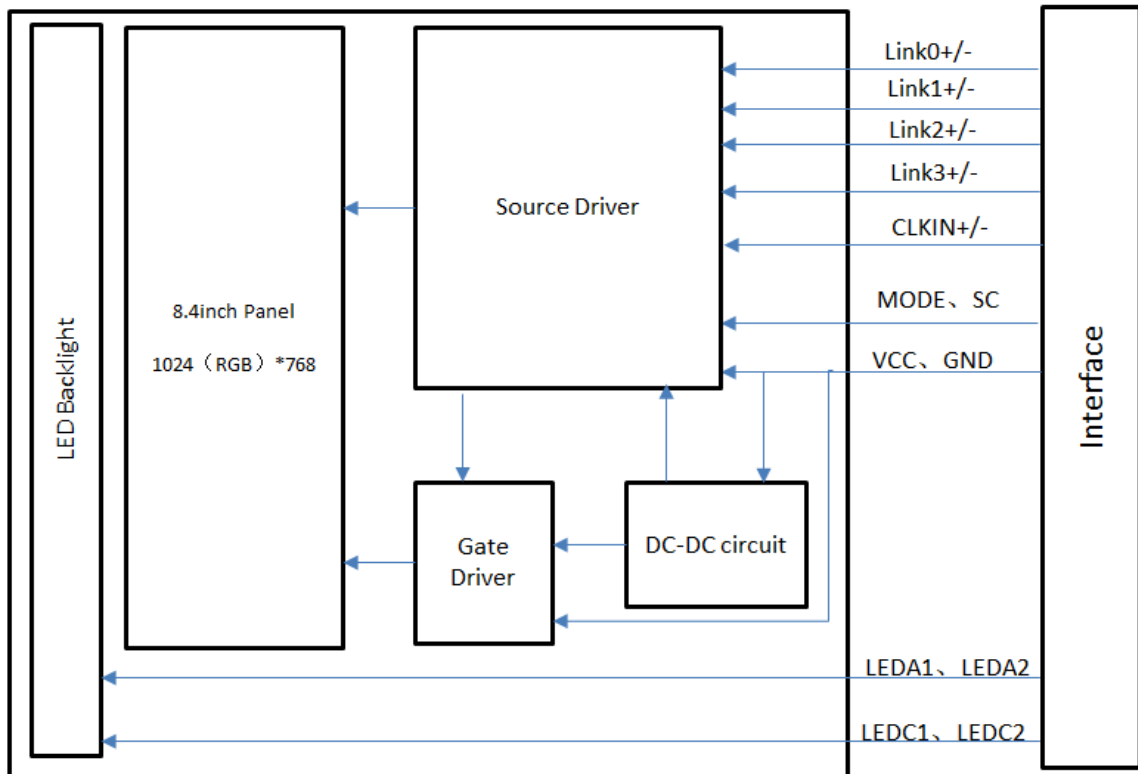
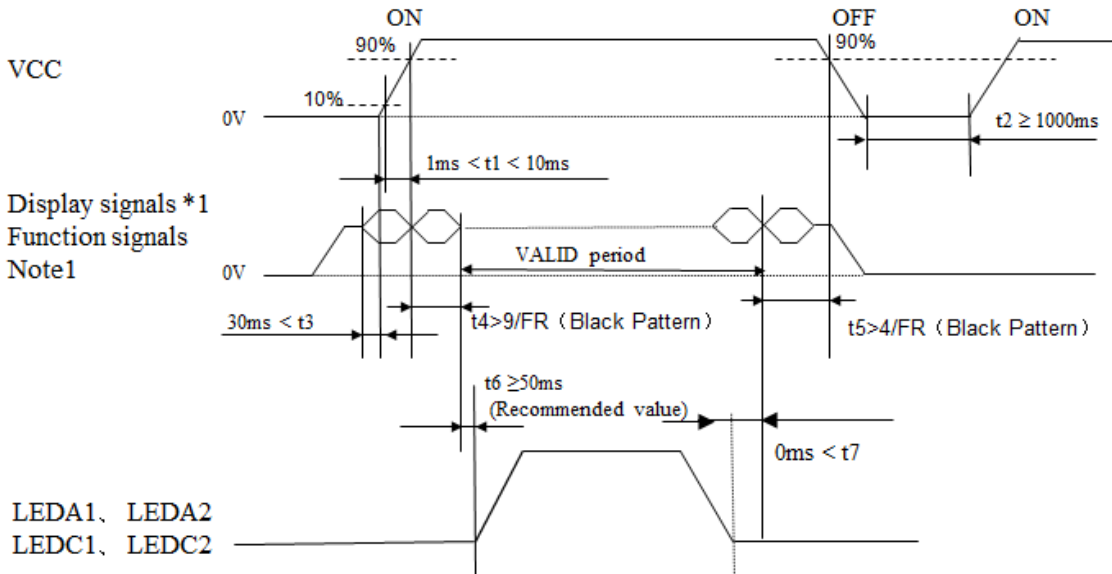

Figure 4.3 LCD Module Block Diagram



**4.4 LCD panel Power ON/OFF sequence**

\*1: Link0+/-, Link1+/-, Link 2+/-, Link 3+/-, CLKIN +/-

Figure 4.4 Power ON/OFF sequence

Note1: If some of display and function signals of this product are cut while this product is working, even if the signal input to it once again, it might not work normally. If a customer stops the display and function signals, VCC also must be shut down.

Note2: The backlight should be turned on within the valid period of display and function signals, in order to avoid unstable data display.

Note3: FR=Frame rate=60Hz.

5 **Timing Chart**

5.1 **LVDS Interface Timing Characteristics**

5.1.1 **LVDS Input Data Format 8-bit LVDS VESA**

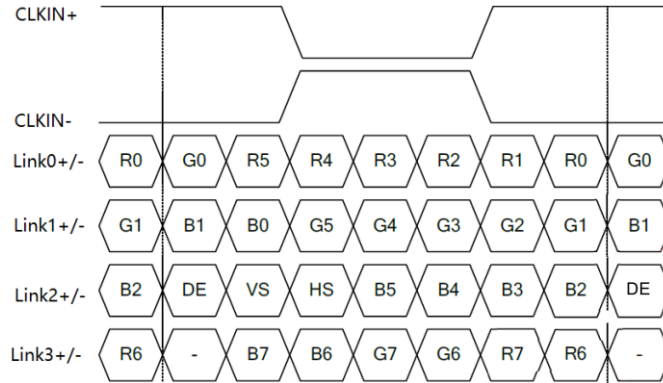

Figure 5.1.1 8-bit LVDS data map

5.1.2 **LVDS Input Data Format 6-bit LVDS VESA**

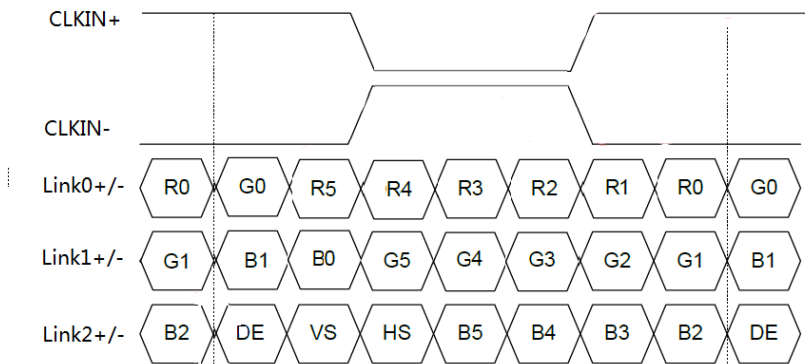

Figure 5.1.2 LVDS data map

5.2 **Input Timing Table**

DE mode for 1024RGB\*768

Parameter	Symbol	Min.	Typ.	Max.	Unit
CLKIN+/- frequency	FCLK	50.3	50.7	65.3	MHz
Horizontal display area	THD	1024			CLK
HS period time	TH	1084	1088	1214	CLK
HS blanking	THFP+THBP	60	64	190	CLK
Vertical display area	TVD	768			H
VS period time	TV	774	776	897	H
VS blanking	TVBP+TVFP	6	8	129	H

Figure5.2 LVDS data parameters

### 5.3 LVDS Input Timing Format

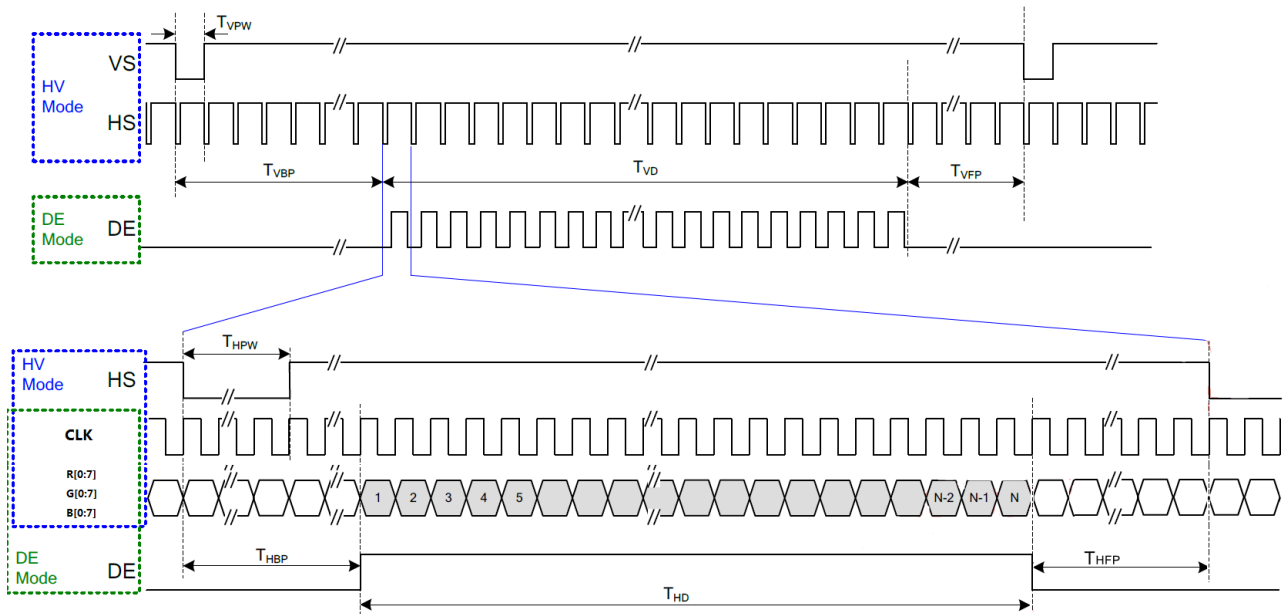

**Figure5.3 Recommended input timing of LVDS transmitter**

Note1: As shown in the figure above, the customer only needs to look at the DE mode section , instead of the SYNC section.

### 5.4 LVDS interface AC characteristic

Parameter	Symbol	Min.	Typ.	Max.	Unit	Condition
Clock frequency	FLVCLK	25	-	85	MHz	Refer to input timing table for each display resolution.
Clock Period	TLVCLK	11.76	-	40	nsec	
Clock high time	TLVCH	-	4/(7* RXFCLK)	-	ns	
Clock low time	TLVCL	-	3/(7* RXFCLK)	-	ns	
Input data skew margin	TRSKM	-	-	0.25	UI	VCC_IF=1.8V w/o SSC
Strobe width	TSW	0.5	-	-	UI	
1 data bit time	UI	-	1/7	-	TLV CLK	
Position 1	TPOS1	-0.25	0	0.25	UI	
Position 0	TPOS0	0.75	1	1.25	UI	
Position 6	TPOS6	1.75	2	2.25	UI	
Position 5	TPOS5	2.75	3	3.25	UI	
Position 4	TPOS4	3.75	4	4.25	UI	
Position 3	TPOS3	4.75	5	5.25	UI	
Position 2	TPOS2	5.75	6	6.25	UI	

**Table 5.4 LVDS interface AC characteristic**

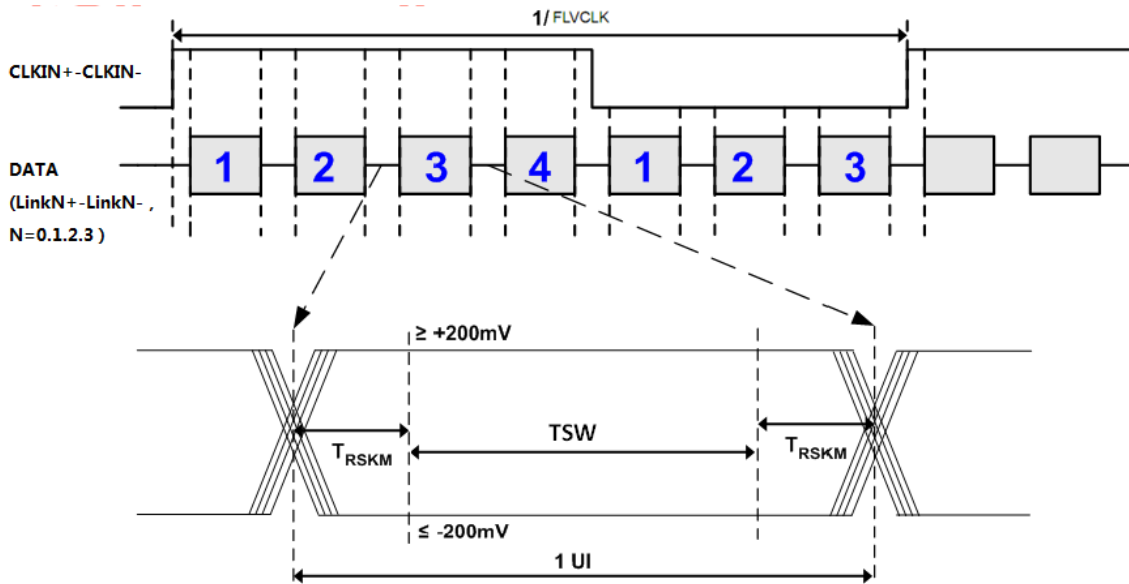

Figure 5.4.1 LVDS Data Skew

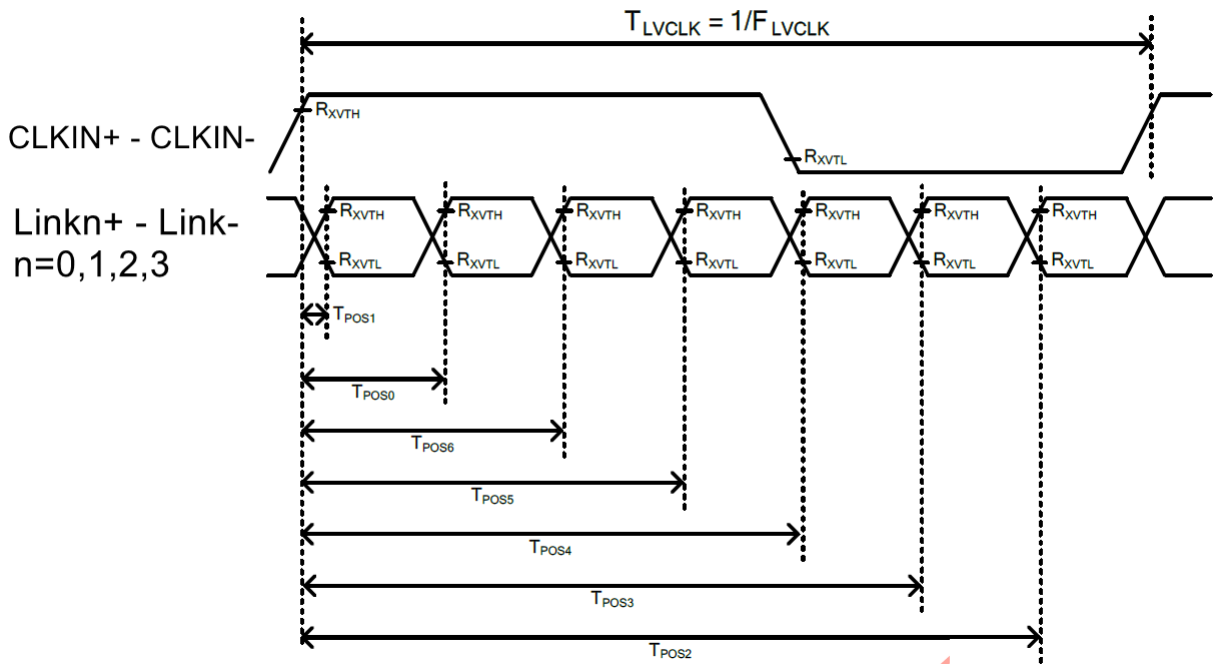

Figure 5.4.2 LVDS input timing

## 6 Optical Characteristics

Item	Symbol	Condition	Min	Typ	Max	Unit	Remark
<b>View Angles</b>	$\theta T$	$CR \geq 10$	80	88	--	Degree	Note2,3
	$\theta B$		80	88	--		
	$\theta L$		80	88	--		
	$\theta R$		80	88	--		
<b>Contrast Ratio</b>	CR	$\theta=0^\circ$	800	1000	--		Note 3
<b>Response Time</b>	$T_{ON}$	25°C	--	25	30	ms	Note 4
	$T_{OFF}$						
<b>Chromaticity</b>	<b>White</b>	x	Backlight is on	0.257	0.307	0.357	Note 1,5
		y		0.283	0.333	0.383	
	<b>Red</b>	x		0.580	0.630	0.680	Note 1,5
		y		0.284	0.334	0.384	
	<b>Green</b>	x		0.266	0.316	0.366	Note 1,5
		y		0.580	0.630	0.680	
	<b>Blue</b>	x		0.107	0.157	0.207	Note 1,5
		y		0.016	0.066	0.116	
<b>Luminance Uniformity</b>	U	-	75	85		%	Note 6
<b>NTSC</b>			65	70	--	%	Note 5
<b>Luminance</b>	L		800	1000		cd/m <sup>2</sup>	Note 7

Test Conditions:

1.  $I_F = 100$  mA, and the ambient temperature is 25°C.
2. The test systems refer to Note 1 and Note 2.

Note 1: Definition of optical measurement system.

The optical characteristics should be measured in dark room. After 5 Minutes operation, the optical properties are measured at the center point of the LCD screen. All input terminals LCD panel must be ground when measuring the center area of the panel.

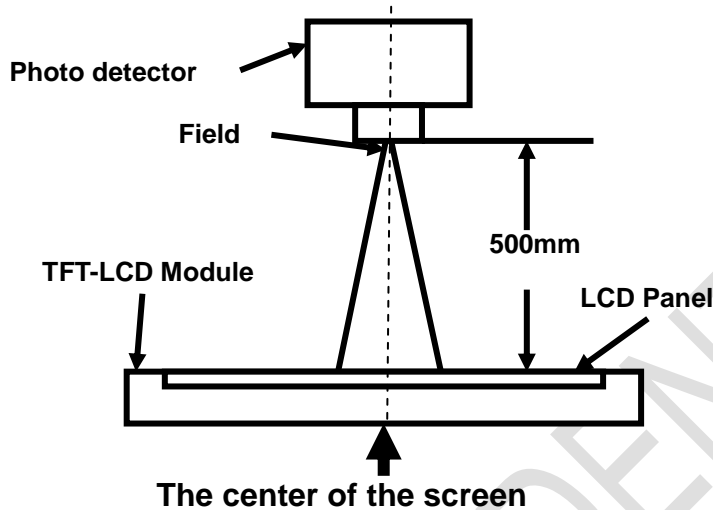

Figure 6.1 Definition of optical measurement system

Note 2: Definition of viewing angle range and measurement system.

viewing angle is measured at the center point of the LCD .

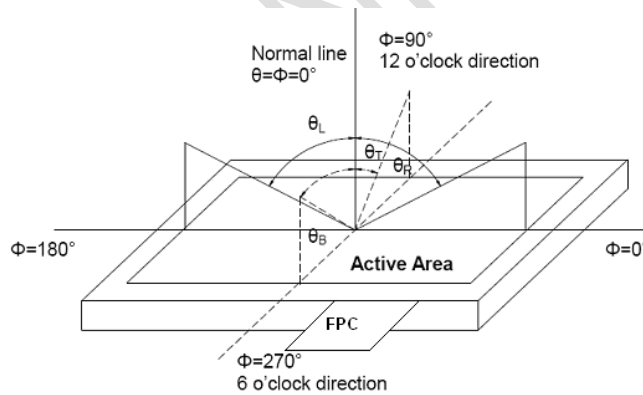

Figure 6.2 Definition of viewing angle

Note 3: Definition of contrast ratio

$$\text{Contrast ratio (CR)} = \frac{\text{Luminance measured when LCD is on the "White" state}}{\text{Luminance measured when LCD is on the "Black" state}}$$

“White state “: The state is that the LCD should drive by Vwhite.

“Black state“: The state is that the LCD should drive by Vblack.

Vwhite: To be determined    Vblack: To be determined.

Note 4: Definition of Response time

The response time is defined as the LCD optical switching time interval between “White” state and “Black” state. Rise time ( $T_{ON}$ ) is the time between photo detector output intensity changed from 90% to 10%. And fall time ( $T_{OFF}$ ) is the time between photo detector output intensity changed from 10% to 90%.

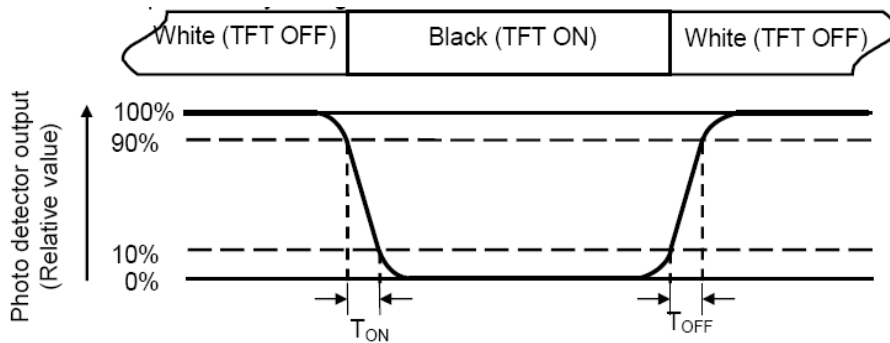

Note 5: Definition of color chromaticity (CIE1931)

Color coordinates measured at center point of LCD.

Note 6: Definition of Luminance Uniformity

Active area is divided into 9 measuring areas (Refer Figure 6.3). Every measuring point is placed at the center of each measuring area.

$$\text{Luminance Uniformity (U)} = L_{\min} / L_{\max}$$

L-----Active area length      W----- Active area width

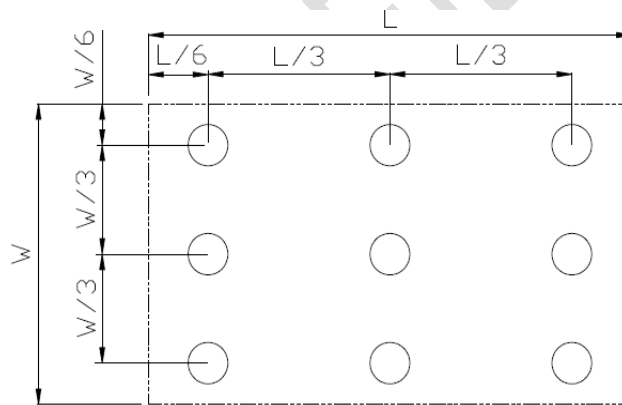

Figure 6.3 Definition of uniformity

$L_{\max}$ : The measured Maximum luminance of all measurement position.

$L_{\min}$ : The measured Minimum luminance of all measurement position.

Note 7: Definition of Luminance:

Measure the luminance of white state at center point.

**7 Environmental / Reliability Test**

No	Test Item	Condition	Remarks
1	High Temperature Operation	Ta = +80°C ,500 hours	IEC60068-2-1 GB2423.2
2	Low Temperature Operation	Ta = -30°C , 500 hours	IEC60068-2-1 GB2423.1
3	High Temperature Storage	Ta = +90°C , 500 hours	IEC60068-2-1 GB2423.2
4	Low Temperature Storage	Ta = -40°C , 500 hours	IEC60068-2-1 GB2423.1
5	Storage at High Temperature and Humidity	Ta = +60°C , 90% RH max,500hours	IEC60068-2-78 GB/T2423.3
6	Thermal Shock (non-operation)	-30°C 30 min~+80°C 30 min, Change time:5min, 100 Cycle	Start with cold temperature, End with high temperature, IEC60068-2-14,GB2423.22
7	ESD	C=150pF,R=330Ω,5point/panel Air:±15KV,5times; Contact:±8KV,5times (Environment:15°C~35°C, 30%RH~60%RH.86Kpa~106Kpa)	IEC61000-4-2 GB/T17626.2
8	Vibration Test (Non Op)	5~100HZ, 19.60m/s <sup>2</sup> 1min/cycle 120times Per X/Y/Z	IEC60068-2-6 GB/T17626.6
9	Mechanical Shock (Non Op)	539m/s <sup>2</sup> , 11ms 5times ±X、±Y、±Z	IEC60068-2-27 GB/T2423.5

Note1: Ts is the temperature of panel's surface.

Note2: Ta is the ambient temperature of sample.

Note3: Before cosmetic and function test, the product must have enough recovery time, at least 2 hours at room temperature.

Note 4: In the standard condition, there shall be no practical problem that may affect the display function. After the reliability test, only guarantee the operation of the product, but don't guarantee all of the cosmetic specification.



# 8 Mechanical Drawing

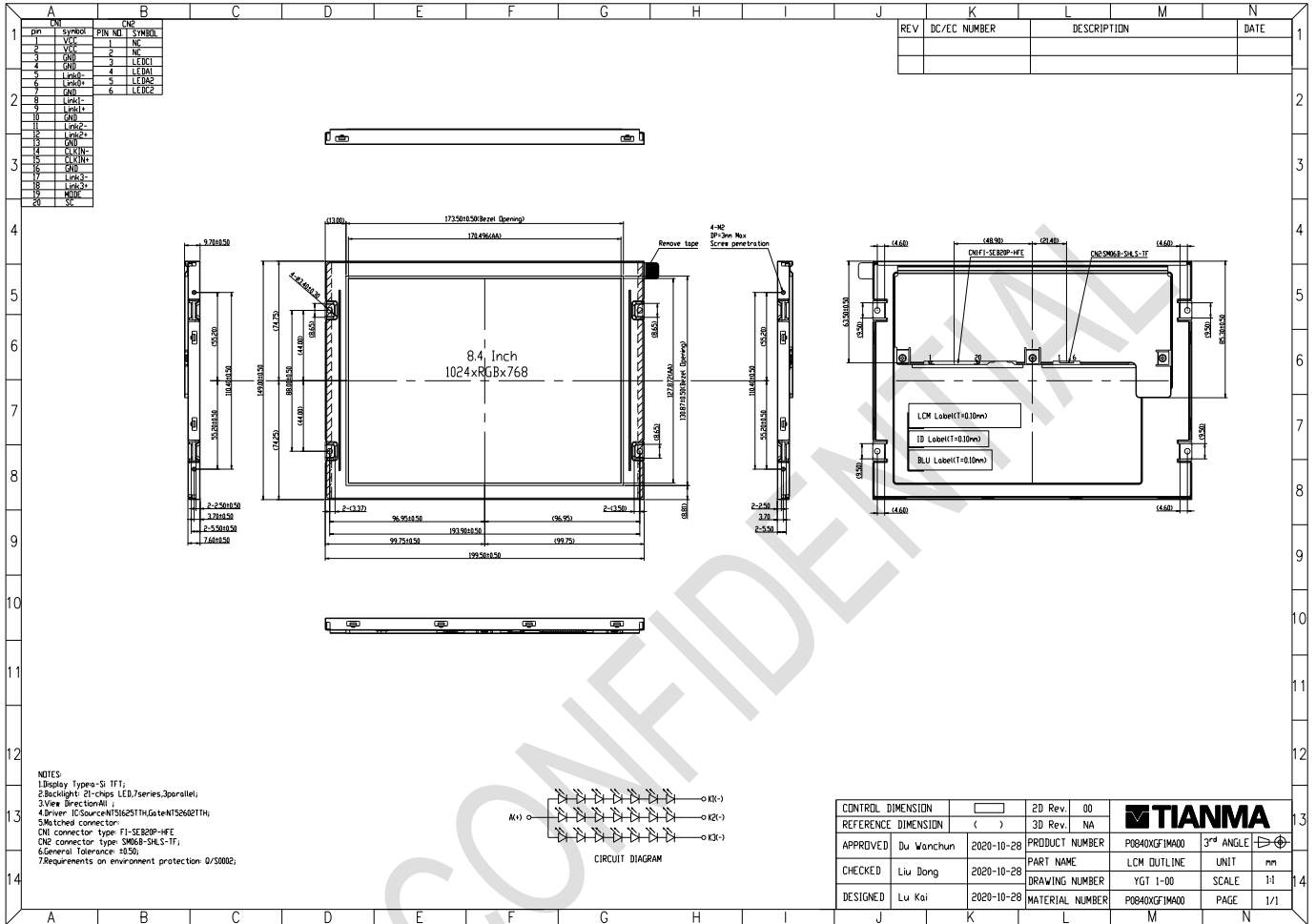

## 9 Packing Drawing

No	Item	Model (Material)	Dimensions(mm)	Unit Weight(Kg)	Quantity	Remark	
1	LCM module	P0840XGF1MA00	173.4×149×9.7	0.303	20		
2	Tray	PET	485×330×25	0.257	12		
3	Dust-proof Bag	PE	700×545×0.05	0.021	1		
4	Carton	Corrugated Paper	544×365×250	1.01	1		
5	BOX	Corrugated Paper	520×345×111	0.38	2		
6	Label		100×52	0.001	1		
7	EPE	EPE	485×330×5	0.016	2		
8	Total weight	10.95Kg ± 5%					

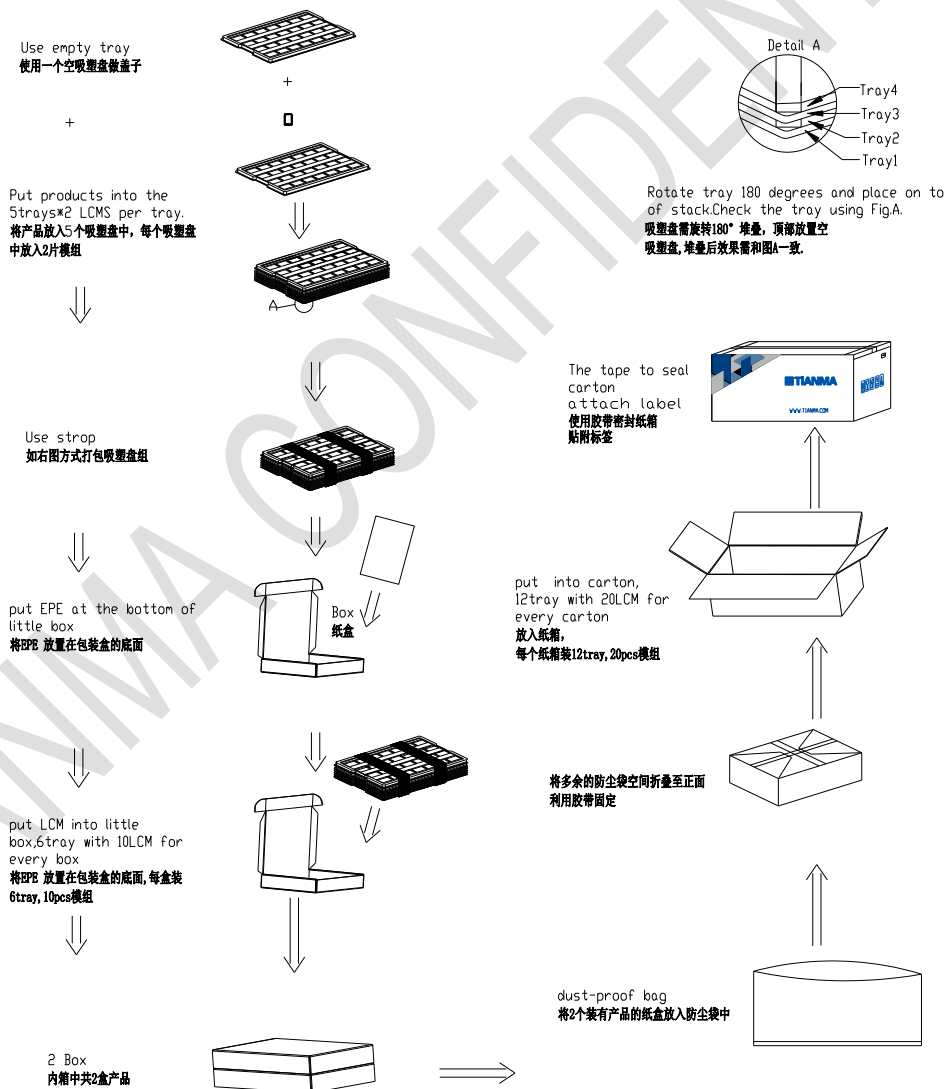

## **10 Precautions for Use of LCD Modules**

### **10.1 Handling Precautions**

10.1.1 The display panel is made of glass. Do not subject it to a mechanical shock by dropping it from a high place, etc.

10.1.2 If the display panel is damaged and the liquid crystal substance inside it leaks out, be sure not to get any in your mouth, if the substance comes into contact with your skin or clothes, promptly wash it off using soap and water.

10.1.3 Do not apply excessive force to the display surface or the adjoining areas since this may cause the color tone to vary.

10.1.4 The polarizer covering the display surface of the LCD module is soft and easily scratched. Handle this polarizer carefully.

10.1.5 If the display surface is contaminated, breathe on the surface and gently wipe it with a soft dry cloth. If still not completely clear, moisten cloth with one of the following solvents:

- Isopropyl alcohol
- Ethyl alcohol

Solvents other than those mentioned above may damage the polarizer. Especially, do not use the following:

- Water
- Ketone
- Aromatic solvents

10.1.6 Do not attempt to disassemble the LCD Module.

10.1.7 If the logic circuit power is off, do not apply the input signals.

10.1.8 To prevent destruction of the elements by static electricity, be careful to maintain an optimum work environment.

10.1.8.1 Be sure to ground the body when handling the LCD Modules.

10.1.8.2 Tools required for assembly, such as soldering irons, must be properly ground.

10.1.8.3 To reduce the amount of static electricity generated, do not conduct assembly and other work under dry conditions.

10.1.8.4 The LCD Module is coated with a film to protect the display surface. Be care when peeling off this protective film since static electricity may be generated.

### **10.2 Storage precautions**

10.2.1 When storing the LCD modules, avoid exposure to direct sunlight or to the light of fluorescent lamps.

10.2.2 The LCD modules should be stored under the storage temperature range. If the LCD modules will be stored for a long time, the recommend condition is:

Temperature : 0°C ~ 40°C Relatively humidity: ≤80%

10.2.3 The LCD modules should be stored in the room without acid, alkali and harmful gas.

### **10.3 Transportation Precautions**

10.3.1 The LCD modules should be no falling and violent shocking during transportation, and also should avoid excessive press, water, damp and sunshine.