

Preliminary Specifications

Final Specifications

Module	15 Inch Color TFT-LCD
Model Name	G150XAB03.0
Note	oTP display

<table style="width: 100%; border-collapse: collapse;"> <thead> <tr> <th style="width: 60%; text-align: left;">Customer</th> <th style="width: 40%; text-align: left;">Date</th> </tr> </thead> <tbody> <tr> <td style="height: 100px; vertical-align: bottom;"> <p>Checked & Approved by</p> <p>_____</p> </td> <td></td> </tr> </tbody> </table>	Customer	Date	<p>Checked & Approved by</p> <p>_____</p>		<table style="width: 100%; border-collapse: collapse;"> <thead> <tr> <th style="width: 60%; text-align: left;">Approved by</th> <th style="width: 40%; text-align: left;">Date</th> </tr> </thead> <tbody> <tr> <td style="text-align: center; vertical-align: middle;"><u>Sean Lin</u></td> <td style="text-align: center; vertical-align: middle;"><u>2019/1/23</u></td> </tr> <tr> <td style="height: 100px; vertical-align: bottom;"> <p>Prepared by</p> <p style="text-align: center;"><u>Jason Hsieh</u></p> </td> <td style="text-align: center; vertical-align: middle;"><u>2018/1/23</u></td> </tr> </tbody> </table>	Approved by	Date	<u>Sean Lin</u>	<u>2019/1/23</u>	<p>Prepared by</p> <p style="text-align: center;"><u>Jason Hsieh</u></p>	<u>2018/1/23</u>
Customer	Date										
<p>Checked & Approved by</p> <p>_____</p>											
Approved by	Date										
<u>Sean Lin</u>	<u>2019/1/23</u>										
<p>Prepared by</p> <p style="text-align: center;"><u>Jason Hsieh</u></p>	<u>2018/1/23</u>										
Customer's sign back page	General Display Business Unit / AU Optronics corporation										

Contents

1. Operating Precautions	4
2. General Description	5
2.1 Display Characteristics.....	5
2.2 Touch Characteristics.....	6
2.3 Optical Characteristics	7
3. Functional Block Diagram	10
4. Absolute Maximum Ratings.....	11
4.1 Absolute Ratings of TFT LCD Module.....	11
4.2 Absolute Ratings of Environment.....	11
5. Electrical Characteristics.....	12
5.1 TFT LCD Module.....	12
5.2 Backlight Unit.....	15
5.3 Touch Sensor Module	15
6. Signal Characteristic.....	16
6.1 Pixel Format Image.....	16
6.2 Scanning Direction.....	16
6.3 Interface Timing	17
6.4 Power ON/OFF Sequence	18
7. Connector & Pin Assignment.....	21
7.1 Connector Description.....	21
7.2 Pin Assignment	21
7.3 Connector Illustration	22
8. Reliability Test Criteria.....	23
9. Mechanical Characteristics	24
9.1 LCM Outline Dimension (Front View and back view)	24
10. Label and Packaging.....	25
10.1 Shipping Label (on the rear side of TFT-LCD display)	25
10.2 Carton Package	25
11. Safety	27
11.1 Sharp Edge Requirements	27
11.2 Materials.....	27
11.3 Capacitors	27
11.4 National Test Lab Requirement	27

1. Operating Precautions

- 1) Since front polarizer is easily damaged, please be cautious and not to scratch it.
- 2) Be sure to turn off power supply when inserting or disconnecting from input connector.
- 3) Wipe off water drop immediately. Long contact with water may cause discoloration or spots.
- 4) When the panel surface is soiled, wipe it with absorbent cotton or soft cloth.
- 5) Since the panel is made of glass, it may be broken or cracked if dropped or bumped on hard surface.
- 6) Since CMOS LSI is used in this module, take care of static electricity and insure human earth when handling.
- 7) Do not open nor modify the module assembly.
- 8) Do not press the reflector sheet at the back of the module to any direction.
- 9) In case if a module has to be put back into the packing container slot after it was taken out from the container, do not press the center of the LED Reflector edge. Instead, press at the far ends of the LED Reflector edge softly. Otherwise the TFT Module may be damaged.
- 10) At the insertion or removal of the Signal Interface Connector, be sure not to rotate nor tilt the Interface Connector of the TFT Module.
- 11) TFT-LCD Module is not allowed to be twisted & bent even force is added on module in a very short time. Please design your display product well to avoid external force applying to module by end-user directly.
- 12) Small amount of materials without flammability grade are used in the TFT-LCD module. The TFT-LCD module should be supplied by power complied with requirements of Limited Power Source (IEC60950-1 or UL60950-1), or be applied exemption.
- 13) Severe temperature condition may result in different luminance, response time.
- 14) Continuous operating TFT-LCD Module under high temperature environment may accelerate LED light bar exhaustion and reduce luminance dramatically.
- 15) The data on this specification sheet is applicable when TFT-LCD module is placed in landscape position.
- 16) Continuous displaying fixed pattern may induce image sticking. It's recommended to use screen saver or moving content periodically if fixed pattern is displayed on the screen.

2. General Description

G150XAB03.0 is a Color Active Matrix Liquid Crystal Display composed of a TFT-LCD display, a driver circuit, and a LED backlight system. The screen format is intended to support 4:3 XGA (1024(H) x 768(V)) screen and 16.2M or 262K colors. All input signals are LVDS interface compatible.

G150XAB03.0 is designed for industrial display applications.

2.1 Display Characteristics

The following items are characteristics summary on the table under 25 °C condition:

Items	Unit	Specifications
Screen Diagonal	[inch]	15
Active Area	[mm]	304.128(H) x 228.096(V)
Pixels H x V		1024x3(RGB) x 768
Pixel Pitch	[mm]	0.297 x 0.297
Pixel Arrangement		RGB Strip
Display Mode		AHVA, Normally Black
Nominal Input Voltage VDD	[Volt]	3.3 typ.
Typical Power Consumption	[Watt]	7.33 (All White Pattern)
Weight	[Grams]	980 (Max.)
Physical Size	[mm]	320.12(H)x 258.4(V) x8.3(D) (max.)
Electrical Interface		eDP
Surface Treatment		Glare
Support Color		16.2M
Temperature Range Operating Storage (Non-Operating)	[°C] [°C]	-20 to +70(+70 °C as panel surface temperature) -20 to +70(+70 °C as panel surface temperature)
RoHS Compliance		RoHS Compliance
Light Bar Unit		LED, Non-replaceable

2.2 Touch Characteristics

The following items are characteristics summary on the table under 25 °C condition:

Item	Unit	Specifications
Type of Touch Sensor		Projective Capacity Touch (on-cell touch)
Cover Lens	Outline Dimension	[mm] 320.12(H) x 258.40(V)
	Material	SDL CS Glass
	Thickness	[mm] 1.10
	Visual Area	[mm] 305.13(H) x 229.10(V)
Touch Sensor	Outline Dimension	on cell touch
	Thickness	on cell touch
	Active Area	306.130 (H) x 230.092(V)
Touch Controller		EETI 3189
Channel (X * Y)	[ch]	55 * 41
Interface		USB 2.0 full speed
Surface Hardness	[H]	3
Multi-Touch Point	Points	10
Single/Multi-points Accuracy	[mm]	Center : +/- 1.5mm Edge : +/- 2.5mm
Linearity	[mm]	Center : +/- 1.5mm Edge : +/- 2.5mm
The smallest distance between 2 points	[mm]	26mm
Report Rate		>100 Hz
OS support		Win 7, Win 8, win10

2.3 Optical Characteristics

The optical characteristics are measured under stable conditions at 25°C (Room Temperature):

Item	Unit	Conditions	Min.	Typ.	Max.	Note	
White Luminance	[cd/m2]		320	400	-	1	
Uniformity	%	9 Points	75	80	-	2, 3	
Contrast Ratio			800	1000	-	4	
Cross talk	%		-	1.2	1.5	5	
Response Time	[msec]	Rising	-			6	
	[msec]	Falling	-				
	[msec]	Raising + Falling	-	25			
Viewing Angle	[degree]	Horizontal CR> = 10	(Right)	80	89	-	7
			(Left)	80	89	-	
	[degree]	Vertical CR> = 10	(Upper)	80	89	-	
			(Lower)	80	89	-	
Color / Chromaticity Coordinates (CIE 1931)		Red x	0.569	0.619	0.669		
		Red y	0.302	0.352	0.402		
		Green x	0.279	0.329	0.379		
		Green y	0.559	0.609	0.659		
		Blue x	0.100	0.150	0.200		
		Blue y	0.068	0.118	0.168		
		White x	0.263	0.313	0.363		
		White y	0.279	0.329	0.379		
Color Gamut	%			60	-		

Note 1: Measurement method

Equipment Pattern Generator, Power Supply, Digital Voltmeter, Luminance meter (SR_3 or equivalent)

Aperture 1° with 50cm viewing distance

Test Point Center

Environment < 1 lux

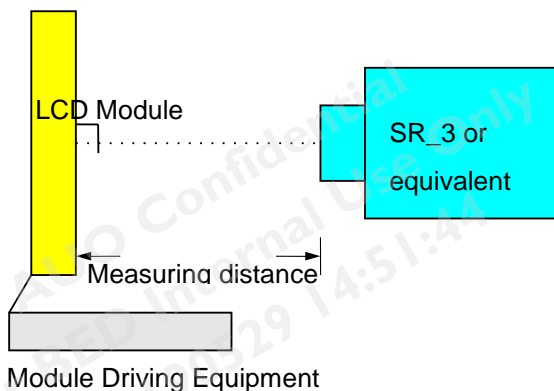

Note 2: Definition of 9 points position (Display active area : 304.128(H) x 228.096(V))

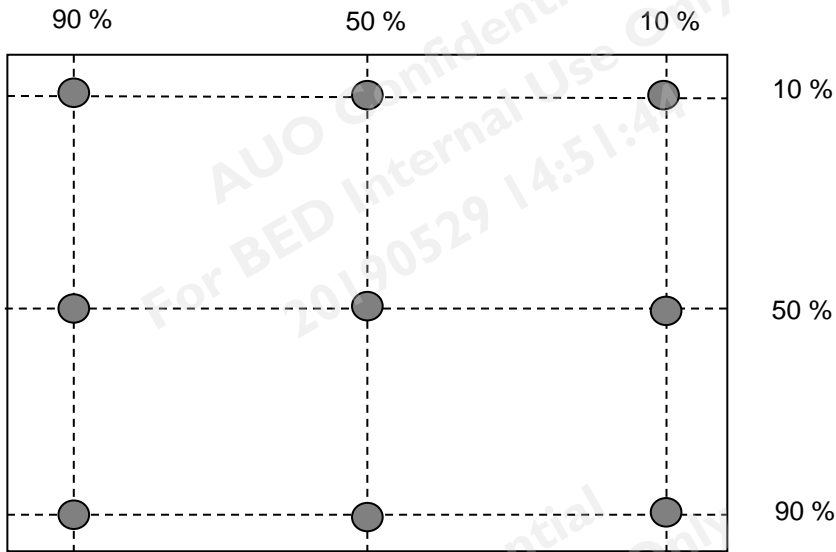

Note 3: The luminance uniformity of 9 points is defined by dividing the minimum luminance values by the maximum test point luminance

$$\delta_{w9} = \frac{\text{Minimum Brightness of nine points}}{\text{Maximum Brightness of nine points}}$$

Note 4 : Definition of contrast ratio (CR):

$$\text{Contrast ratio (CR)} = \frac{\text{Brightness on the "White" state}}{\text{Brightness on the "Black" state}}$$

Note 5 : Definition of cross talk (CT)

$$CT = \max(| Y' - Y | / Y \times 100 (\%)), Y = U/D/L/R$$

Where

Y = Luminance of measured location without gray level 0 pattern (cd/m²)

Y' = Luminance of measured location with gray level 0 pattern (cd/m²)

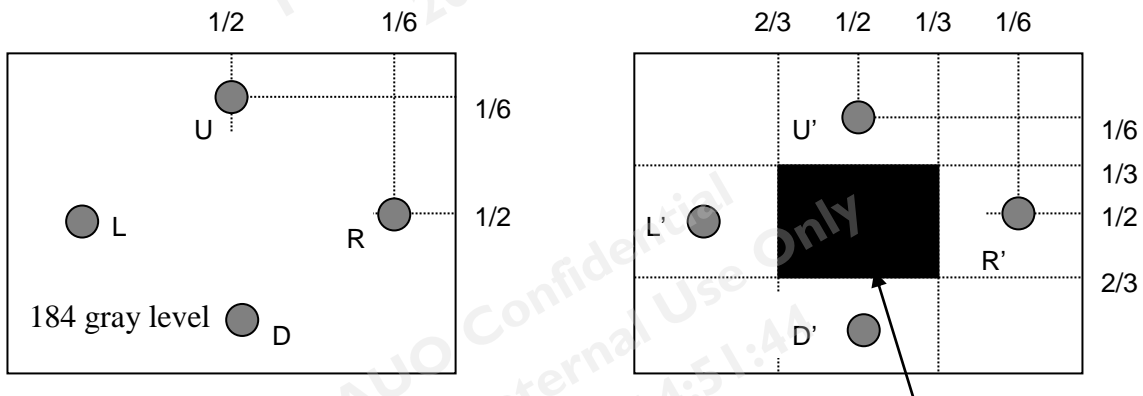

Note 6: Definition of response time:

The output signals of photo detector are measured when the input signals are changed from "White" to "Black" (falling time) and from "Black" to "White" (rising time), respectively. The response time interval is between 10% and 90% of amplitudes. Please refer to the figure as below.

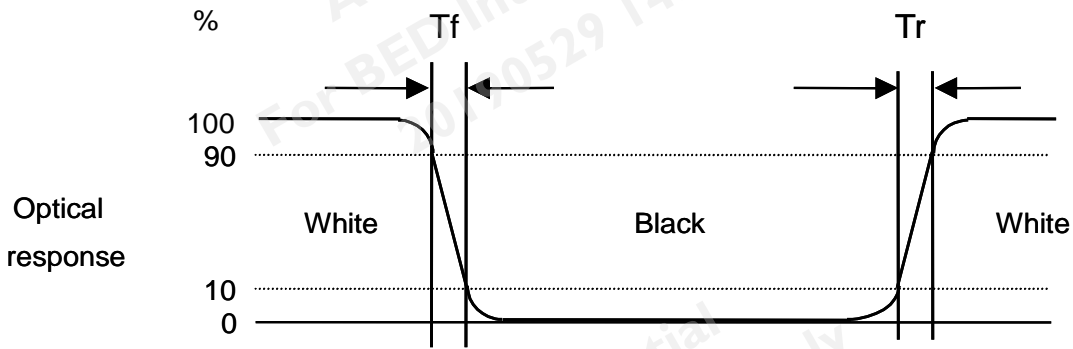

Note 7: Definition of viewing angle

Viewing angle is the measurement of contrast ratio ≥ 10 , at the screen center, over a 180° horizontal and 180° vertical range (off-normal viewing angles). The 180° viewing angle range is broken down as below: 90° (θ) horizontal left and right, and 90° (Φ) vertical high (up) and low (down). The measurement direction is typically perpendicular to the display surface with the screen rotated to its center to develop the desired measurement viewing angle.

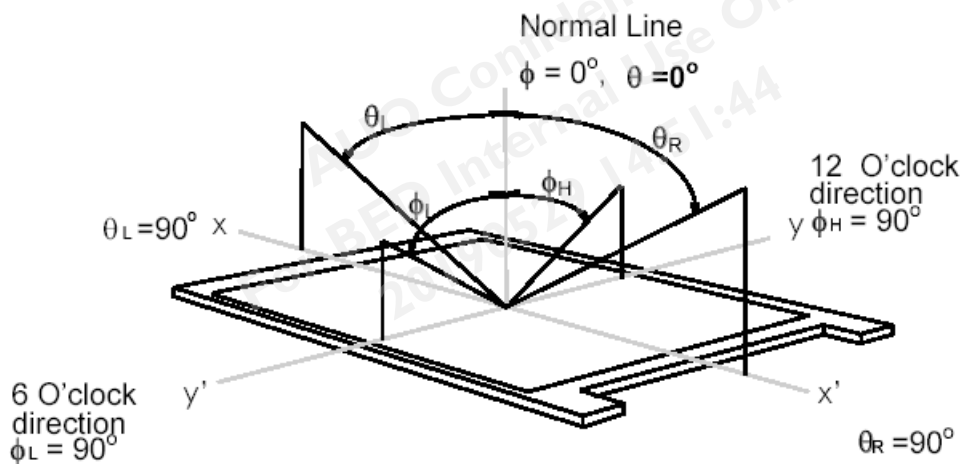

3. Functional Block Diagram

The following diagram shows the functional block of the 15 inch color TFT/LCD module:

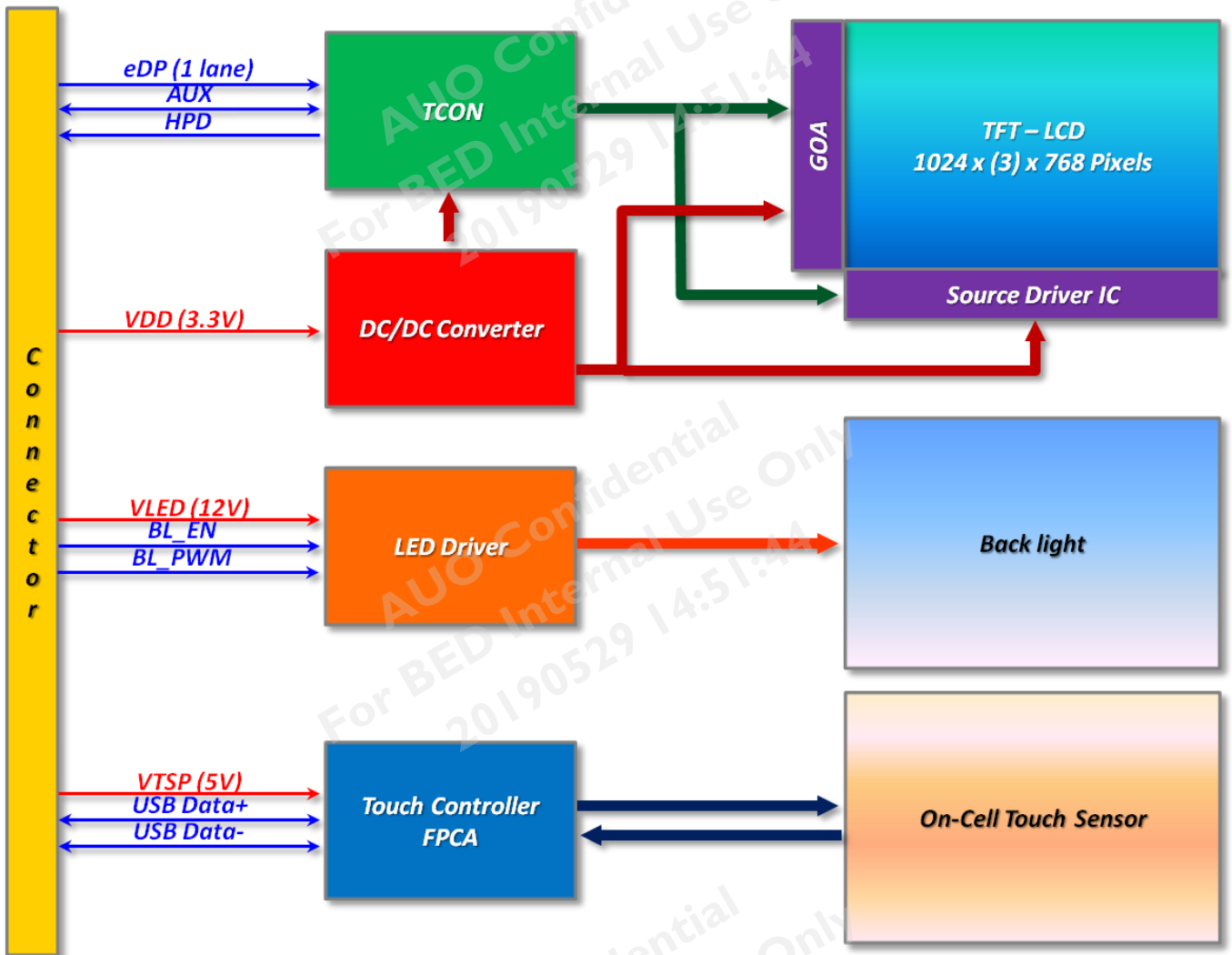

4. Absolute Maximum Ratings

4.1 Absolute Ratings of TFT LCD Module

Item	Symbol	Min	Max	Unit
Logic/LCD Drive Voltage	Vin	-0.3	+3.6	[Volt]

4.2 Absolute Ratings of Environment

Item	Symbol	Min	Max	Unit
Operating Temperature	TOP	-20	+70	[°C]
Operation Humidity	HOP	8	90	[%RH]
Storage Temperature	TST	-20	+70	[°C]
Storage Humidity	HST	8	90	[%RH]

Note: Maximum Wet-Bulb should be 39°C and no condensation.

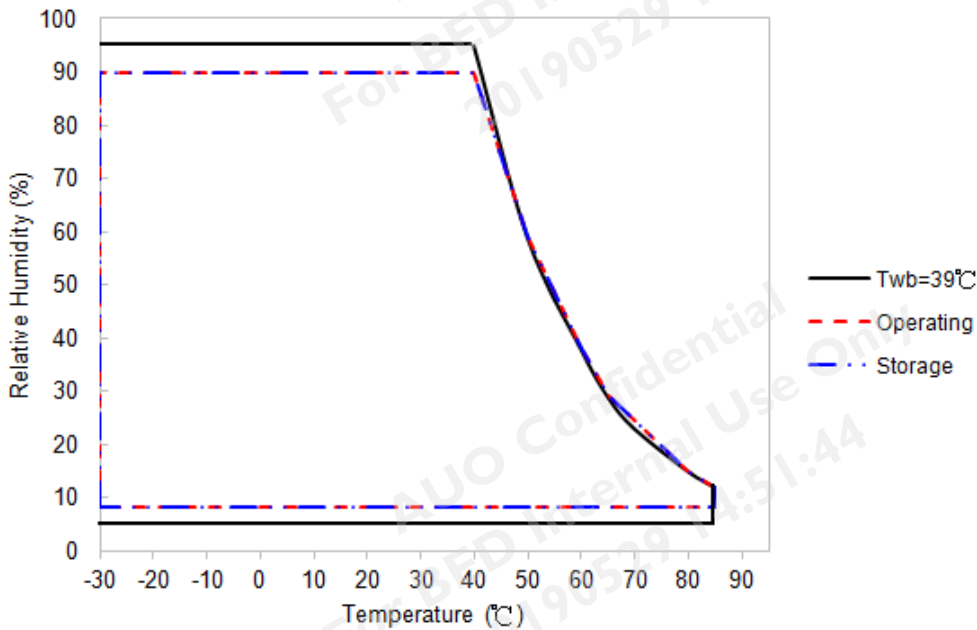

5. Electrical Characteristics

5.1 TFT LCD Module

5.1.1 Power Specification

Symbol	Parameter	Min	Typ	Max	Units	Remark
VDD	Logic/LCD Drive Voltage	3.0	3.3	3.6	[Volt]	± 10%
IDD	VDD Current	-	0.43	0.52	[A]	All White Pattern (VDD=3.3V, at 60Hz)
Irush	LCD Inrush Current	-	-	3	[A]	Note 1
PDD	VDD Power	-	1.42	1.72	[Watt]	All White Pattern (VDD=3.3V, at 60Hz)

Note 1: Measurement condition:

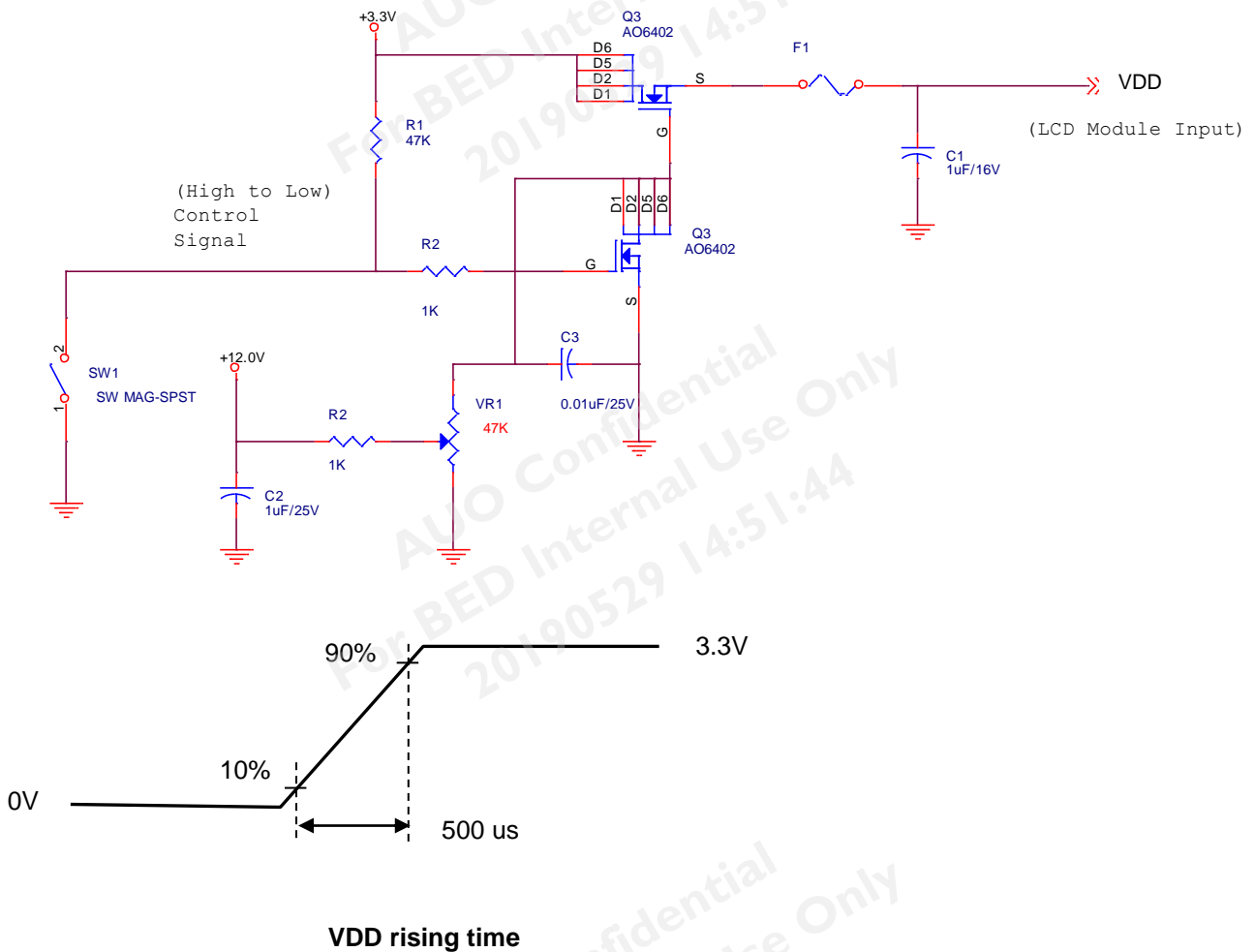

5.1.2 Signal Electrical Characteristics

Signal electrical characteristics are as follows:

Display Port main link signal:

Differential pair VD+ , VD-
Which is one Display port
Main link

VCM of Display port
Main link

$$V_{diff_{P-P}} = [(VD+) - (VD-)] \times 2$$

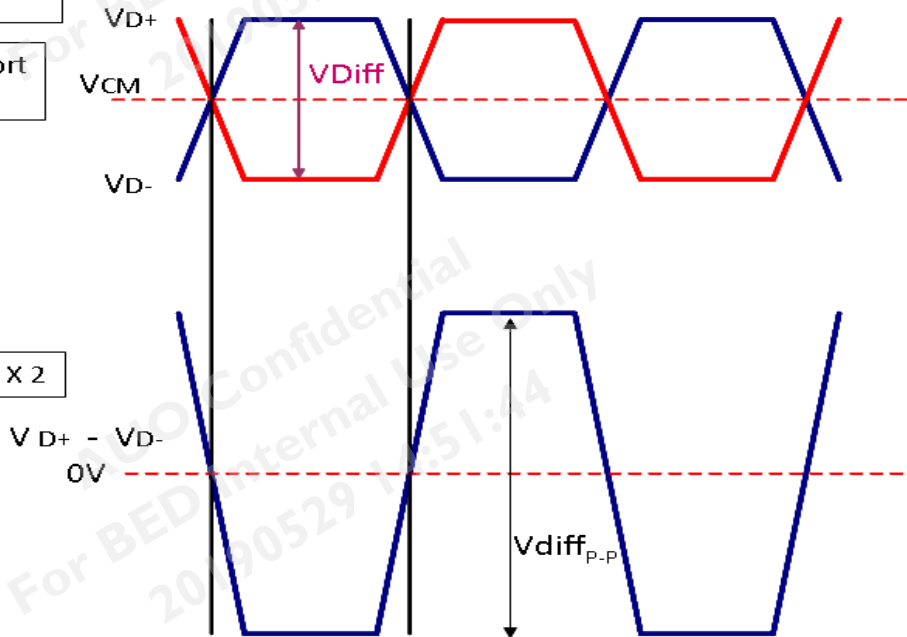

Display port main link					
		Min	Typ	Max	unit
VCM	RX input DC Common Mode Voltage		0		V
VDiff _{P-P}	Peak-to-peak Voltage at a receiving Device	150		1320	mV

Follow as VESA display port standard V1.1a

Display Port AUX_CH signal:

Differential AUX+ , AUX-
Which is Display port AUX_CH

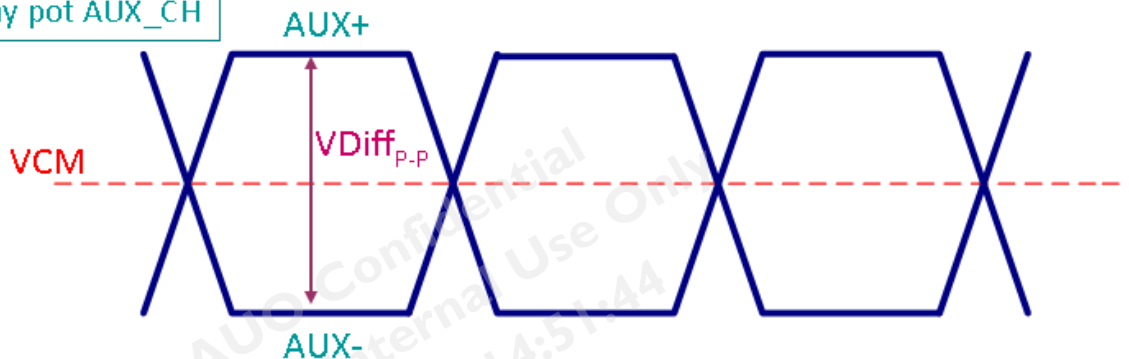

Display port AUX_CH					
		Min	Typ	Max	unit
VCM	AUX DC Common Mode Voltage		0		V
VDiff _{P-P}	AUX Peak-to-peak Voltage at a receiving Device	0.4	0.6-	0.8	V

Follow as VESA display port standard V1.1a.

Display Port VHPD signal:

Display port VHPD					
		Min	Typ	Max	unit
VHPD	HPD Voltage	2.25	2.5	2.75	V

Follow as VESA display port standard V1.1a.

5.2 Backlight Unit

Following characteristics are measured under stable condition using a LED driving board at 25°C (Room Temperature).

Symbol	Parameter	Min.	Typ.	Max.	Unit	Remark
V _{cc}	Input Voltage	10.8	12	13.2	Volt	
I _{vcc}	Input Current	-	0.49	0.54	A	100% Dimming
P _{LED}	Power Consumption	-	5.91	6.48	Watt	100% Dimming
I _{rush}	Inrush Current			2	A	
V _{LED on/off}	On Control Voltage	2.5	3.3	5.5	Volt	
	Off Control Voltage			0.5	Volt	
FPWM	PWM Dimming Frequency	200		10k	Hz	
	High Voltage	2.5	3.3	5.5	Volt	
	Low Voltage			0.5	Volt	
	Dimming Duty Cycle	5	-	100	%	
I _F	LED Forward Current		60		mA	Ta = 25°C
Operating Life		50,000			Hrs	Ta = 25°C

Note 1: Ta means ambient temperature of TFT-LCD module.

Note 2: If G150XAB03.0 module is driven at high ambient temperature & humidity condition. The operating life will be reduced.

Note 3: Definition of life time: LED brightness becomes 50% of its original value. The minimum life time of LED unit is defined at the condition of I_{RLED} = 60 mA and 25±2°C (Room temperature).

5.3 Touch Sensor Module

5.3.1 Power Specification

Items	Symbol	Specifications			Unit	Notes
		Min.	Typ.	Max.		
Touch Panel Power Supply	VTSP	4.5	5	5.5	V	Ripple <100mV
Input Voltage	V _{IH}	V _{DD} -0.8	-	-	V	V _{DD} =3.3
	V _{LIL}	-	-	0.8	V	
VTSP Current		-	91.21	109.45	mA	Active mode @ Report rate 100Hz

6. Signal Characteristic

6.1 Pixel Format Image

Following figure shows the relationship between input signal and LCD pixel format.

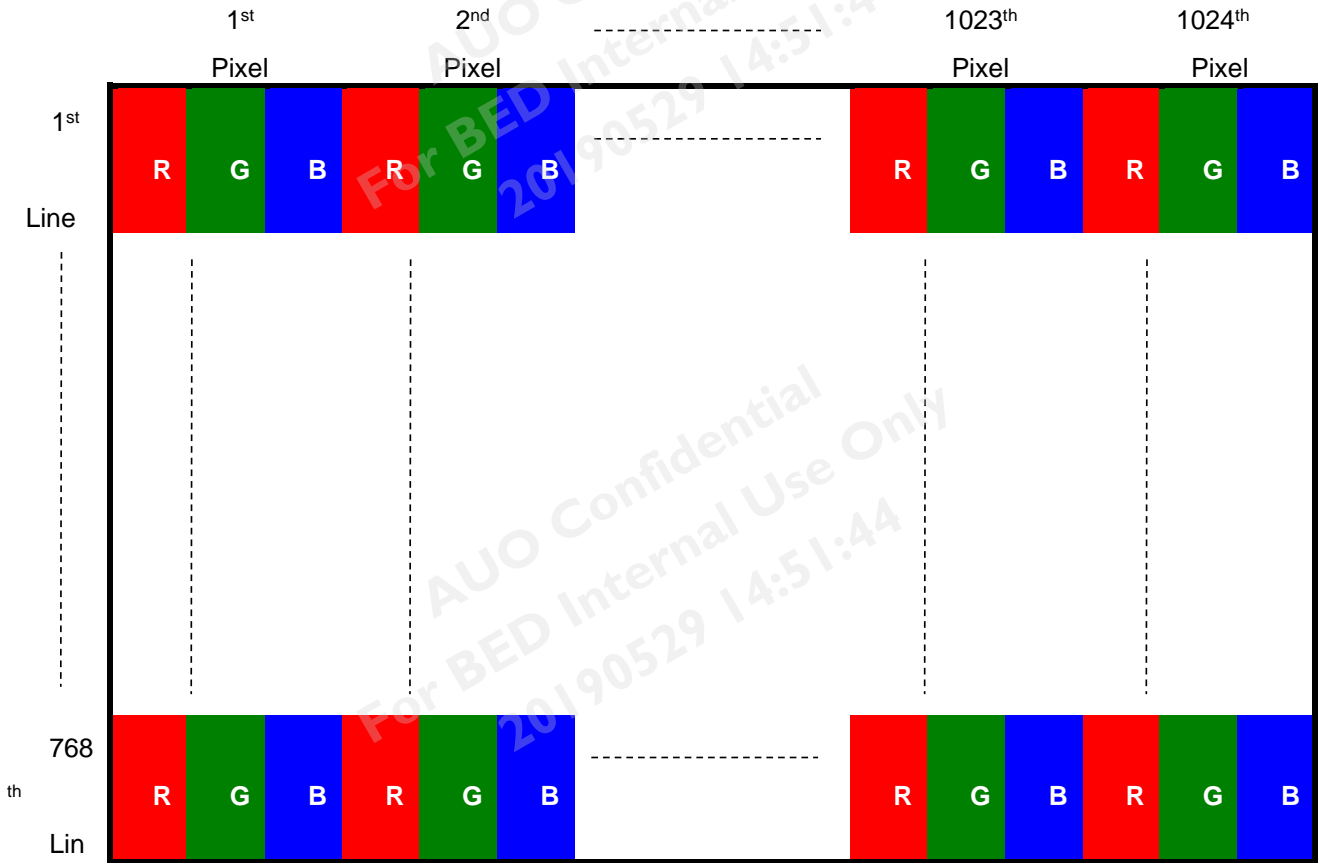

6.2 Scanning Direction

The following figures show the image seen from the front view. The arrow indicates the direction of scan.



6.3 Interface Timing

Timing Characteristics

Signal	Parameter	Symbol	Min.	Typ.	Max.	Unit	
Clock Timing	Clock frequency	$1/T_{Clock}$	63	65	67	MHz	
Vsync Timing	Vertical Section	Period	T_V	804	806	808	T_{Line}
		Active	T_{VD}	768	768	768	
		Blanking	T_{VB}	36	38	40	
Hsync Timing	Horizontal Section	Period	T_H	1328	1344	1360	T_{Clock}
		Active	T_{HD}	1024	1024	1024	
		Blanking	T_{HB}	304	320	336	
Frame Rate		F	59	60	61	Hz	

Note: Support DE mode only.

Note: Typical value refer to VESA STANDARD

6.4 Power ON/OFF Sequence

Display Port panel power sequence:

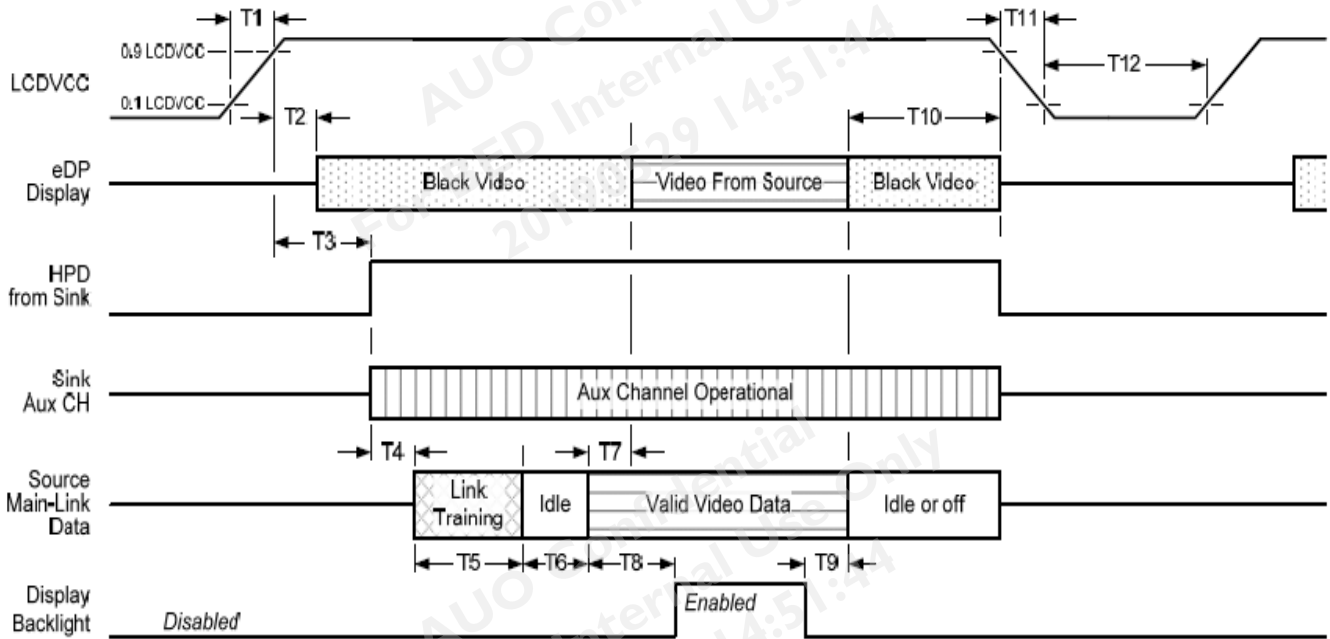

Display port interface power up/down sequence, normal system operation

Display Port AUX_CH transaction only:

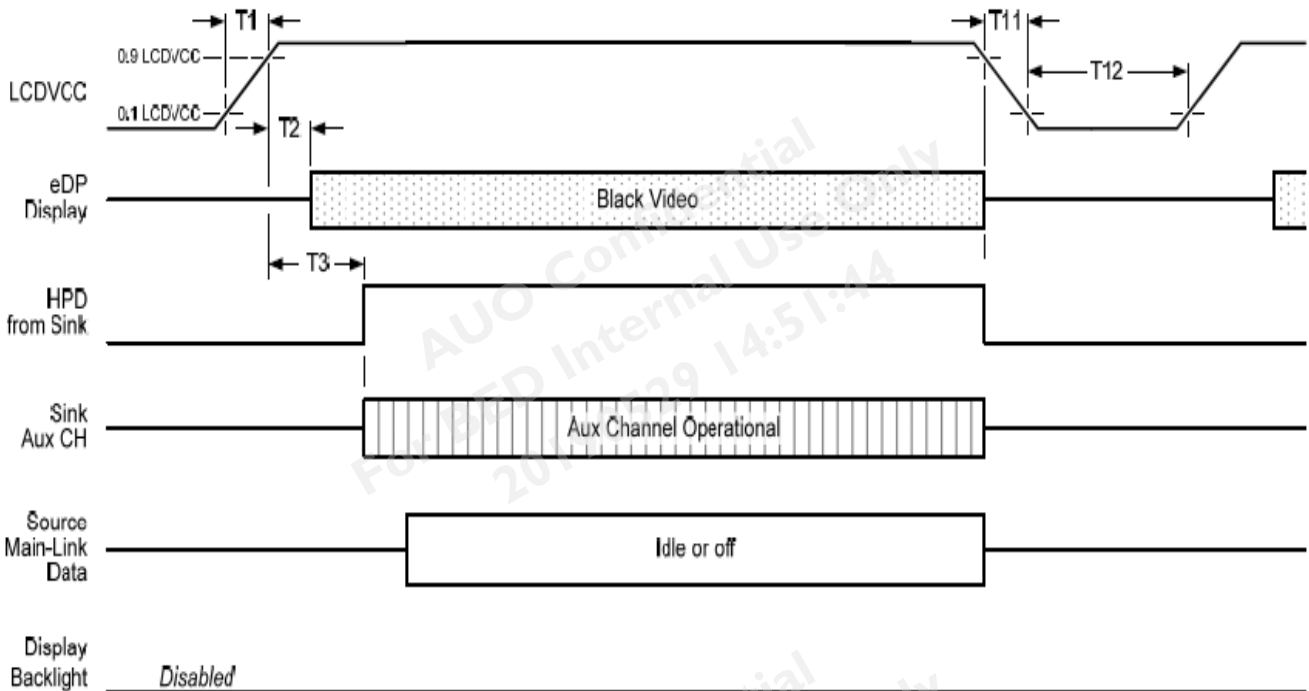

Display port interface power up/down sequence, AUX_CH transaction only

Display Port panel power sequence timing parameter:

Timing parameter	Description	Reqd. by	Limits			Notes
			Min.	Typ.	Max.	
T1	power rail rise time, 10% to 90%	source	0.5ms		10ms	
T2	delay from LCDVDD to black video generation	sink	0ms		200ms	prevents display noise until valid video data is received from the source
T3	delay from LCDVDD to HPD high	sink	0ms		200ms	sink AUX_CH must be operational upon HPD high.
T4	delay from HPD high to link training initialization	source				allows for source to read link capability and initialize.
T5	link training duration	source				dependant on source link to read training protocol.
T6	link idle	source				Min accounts for required BS-Idle pattern. Max allows for source frame synchronization.
T7	delay from valid video data from source to video on display	sink	0ms		50ms	max allows sink validate video data and timing.
T8	delay from valid video data from source to backlight enable	source				source must assure display video is stable.
T9	delay from backlight disable to end of valid video data	source				source must assure backlight is no longer illuminated.
T10	delay from end of valid video data from source to power off	source	0ms		500ms	
T11	power rail fall time, 90% to 10%	source			200ms	
T12	power off time	source	500ms			

Note 1: The sink must include the ability to generate black video autonomously. The sink must automatically enable black video under the following conditions:
 -upon LCDVDD power on (with in T2 max)-when the "Novideostream_Flag" (VB-ID Bit 3) is received from the source (at the end of T9).

-when no main link data, or invalid video data, is received from the source. Black video must be displayed within 64ms (typ) from the start of either condition. Video data can be deemed invalid based on MSA and timing information, for example.

Note 2: The sink may implement the ability to disable the black video function, as described in Note 1, above, for system development and debugging purpose.

Note 3: The sink must support AUX_CH polling by the source immediately following LCDVDD power on without causing damage to the sink device (the source can re-try if the sink is not ready). The sink must be able to respond to an AUX_CH transaction with the time specified within T3 max.

Display Port panel B/L power sequence timing parameter:

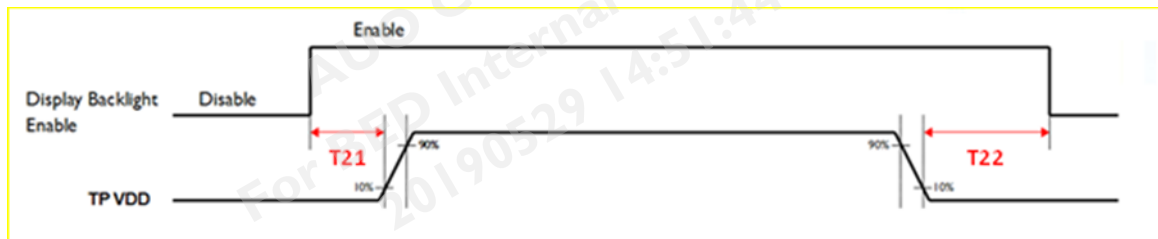
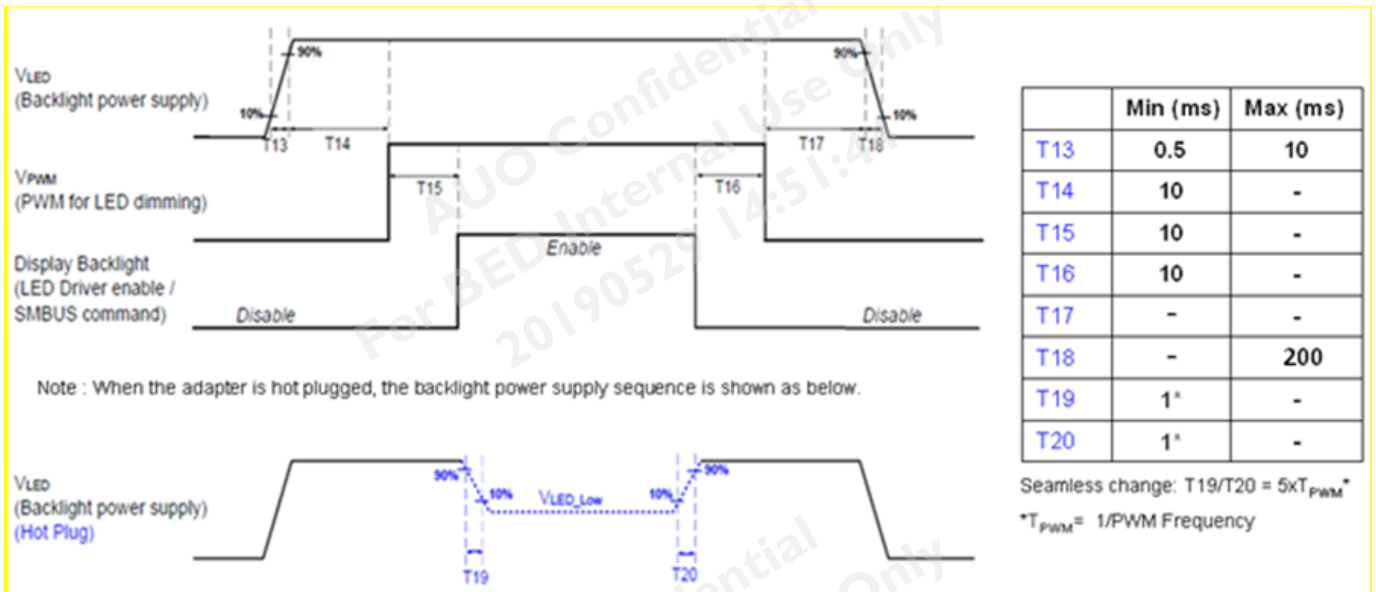

TP Power ON/OFF sequence timing

parameter	Value		Units
	Min	Max	
T21	10	-	[ms]
T22	100	-	[ms]

The above on/off sequence should be applied to avoid abnormal function in the display. Please make sure to turn off the power when you plug the cable into the input connector or pull the cable out of the connector.

7. Connector & Pin Assignment

Physical interface is described as for the connector on module. These connectors are capable of accommodating the following signals and will be following components.

7.1 Connector Description

Connector Name / Designation	Signal Connector
Manufacturer	I-PEX or Compatible
Connector Model Number	20765-040E-11A or compatible
Mating Model Number	20453-040T-11 or compatible

7.2 Pin Assignment

Pin No.	Name	Function
1	NC	No Connect
2	NC	No Connect
3	NC	No Connect
4	NC	No Connect
5	NC	No Connect
6	VTSP	Touch Power (Typ. 5V)
7	VTSP	Touch Power (Typ. 5V)
8	TP_GND	Touch Ground
9	TP_DP	USB Data+ for Touch
10	TP_DN	USB Data- for Touch
11	NC	No Connect
12	BL_PWR	Backlight Power (Typ. 12V)
13	BL_PWR	Backlight Power (Typ. 12V)
14	BL_PWR	Backlight Power (Typ. 12V)
15	BL_PWR	Backlight Power (Typ. 12V)
16	NC	No Connect
17	NC	No Connect
18	BL_PWM	System PWM Signal Input
19	BL_Enable	Backlight On / Off
20	BL_GND	Backlight Ground
21	BL_GND	Backlight Ground
22	BL_GND	Backlight Ground
23	BL_GND	Backlight Ground
24	HPD	HPD (Hot Plug Detect) Signal
25	LCD GND	LCD Logic and Driver Ground
26	LCD GND	LCD Logic and Driver Ground

27	NC	No Connect
28	LCD_PWR	LCD Logic and Driver Power
29	LCD_PWR	LCD Logic and Driver Power
30	H_GND	High Speed Ground
31	AUX_N	Comp Signal Auxiliary Channel
32	AUX_P	True Signal Auxiliary Channel
33	H_GND	High Speed Ground
34	Lane0_P	True Signal Link Lane 0
35	Lane0_N	Comp Signal Link Lane 0
36	H_GND	High Speed Ground
37	NC	No Connect
38	NC	No Connect
39	H_GND	High Speed Ground
40	NC	No Connect

7.3 Connector Illustration

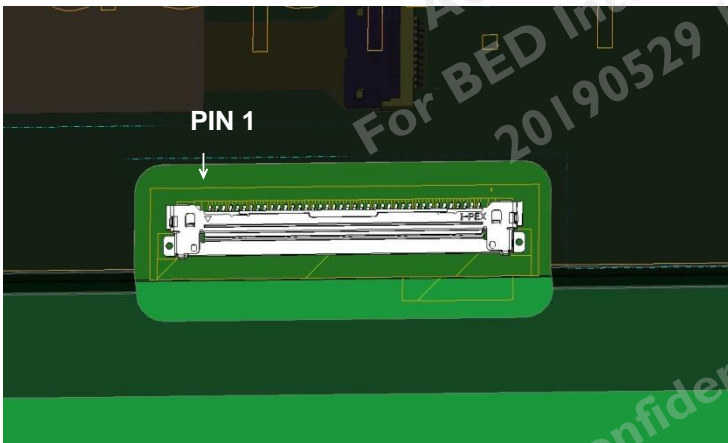

8. Reliability Test Criteria

Items	Required Condition	Note
Temperature Humidity Bias	50°C/80%,300 hours	
High Temperature Operation	70°C,300 hours	
Low Temperature Operation	-20°C,300 hours	
Hot Storage	70°C,300 hours	
Cold Storage	-20°C,300 hours	
Thermal Shock Test	-20°C/30 min ,60°C/30 min ,100cycles	
Shock Test (Non-Operating)	50G,20ms,Half-sine wave,(±X, ±Y, ±Z)	
Vibration Test (Non-Operating)	1.5G, (10~200Hz, P-P) 30 mins/axis (X, Y, Z)	
On/off test	On/10 sec, Off/10 sec, 30,000 cycles	
ESD	Contact Discharge: ± 8KV, 150pF(330Ω) 1sec, 8 points, 25 times/ point Air Discharge: ± 15KV, 150pF(330Ω) 1sec, 8 points, 25 times/ point	Note 1

Note1: According to EN61000-4-2, ESD class B: Some performance degradation allowed. No data lost
 . Self-recoverable. No hardware failures.

Note 2:

- Water condensation is not allowed for each test items.
- Each test is done by new TFT-LCD module. Don't use the same TFT-LCD module repeatedly for reliability test.
- The reliability test is performed only to examine the TFT-LCD module capability.
- To inspect TFT-LCD module after reliability test, please store it at room temperature and room humidity for 24 hours at least in advance.
- No function failure occurs. Mura shall be ignored after high temperature reliability test

9. Mechanical Characteristics

9.1 LCM Outline Dimension (Front View and back view)

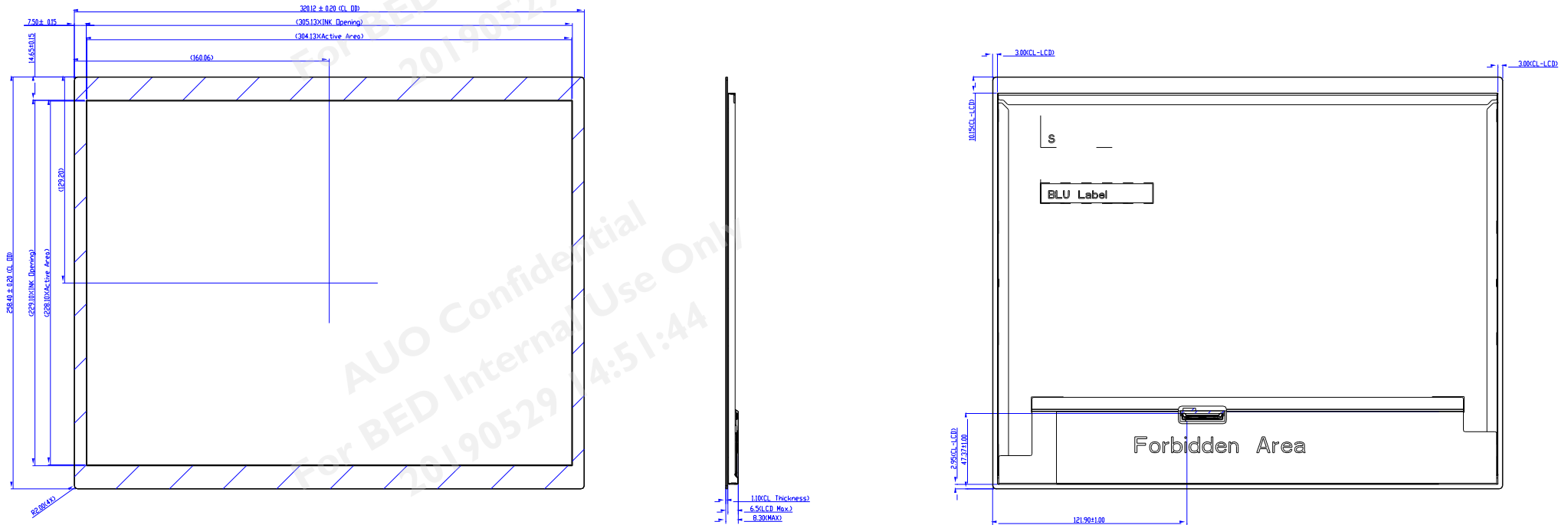

10. Label and Packaging

10.1 Shipping Label (on the rear side of TFT-LCD display)

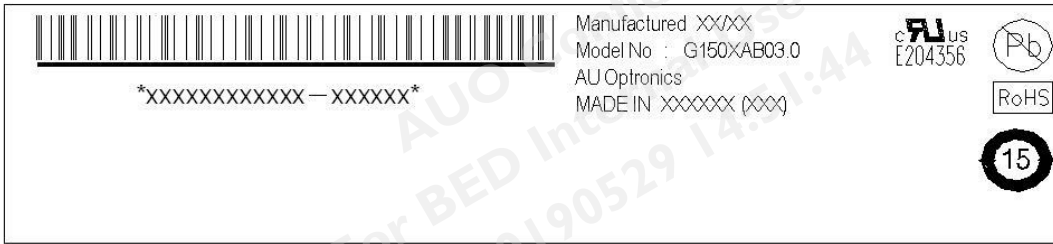

10.2 Carton Package



PP Board

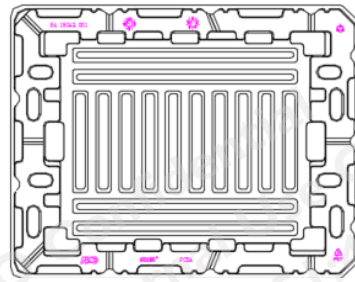

TRAY put on PP Board

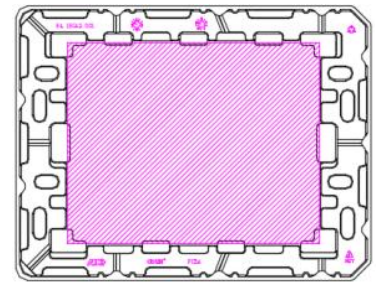

1 TRAY with 1 TTL Panel

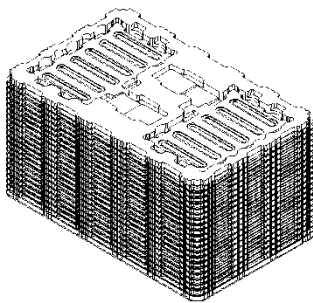

Total 10 pcs TTL panel,
Top put 1 empty TRAY



Total 11 pcs TRAY put into
ESD Bag



Put EPE cushion into carton



Put top EPE pad



Tape carton
10 pcs/carton



Max capacity : 15 TFT-LCD module per carton

Max weight: 10.0 kg per carton

Outside dimension of carton: 508(L) mm x 408(W) mm x 279(H) mm

Pallet size : 1150mm*840mm*132mm 0mm*890mm*132mm

AUO Confidential
For BED Internal Use Only
20190529 14:51:44

AUO Confidential
For BED Internal Use Only
20190529 14:51:44

AUO Confidential
For BED Internal Use Only
20190529 14:51:44

AUO Confidential
For BED Internal Use Only
20190529 14:51:44

11. Safety

11.1 Sharp Edge Requirements

There will be no sharp edges or comers on the display assembly that could cause injury.

11.2 Materials

11.2.1 Toxicity

There will be no carcinogenic materials used anywhere in the display module. If toxic materials are used, they will be reviewed and approved by the responsible AUO toxicologist.

11.2.2 Flammability

All components including electrical components that do not meet the flammability grade UL94-V1 in the module will complete the flammability rating exception approval process.

The printed circuit board will be made from material rated 94-V1 or better. The actual UL flammability rating will be printed on the printed circuit board.

11.3 Capacitors

If any polarized capacitors are used in the display assembly, provisions will be made to keep them from being inserted backwards.

11.4 National Test Lab Requirement

The display module will satisfy all requirements for compliance to:

UL 60950-1, Second Edition

U.S.A. Information Technology Equipment