

EV_MOD_CH101 Evaluation Module User Guide

TABLE OF CONTENTS

1 Scope and Purpose..... 3

2 EV_MOD_CH101 Evaluation Module Board 4

 2.1 Pin Assignments 4

 2.2 Electrical Specifications..... 4

 2.3 Schematic..... 4

 2.4 Bill of Materials 5

3 Configuration, Programming, and Operation 6

 3.1 Configuration and Programming..... 6

 3.2 Operation 6

4 Mechanical Specifications 7

5 Sensor Mounting and Beam Patterns 8

 5.1 Sensor Mounting..... 8

 5.2 Beam Patterns..... 8

6 Revision History 10

LIST OF FIGURES

Figure 1. View of EV_MOD_CH101 evaluation module with an omnidirectional acoustic housing 3

Figure 2. EV_MOD_CH101 Schematic..... 4

Figure 3. EV_MOD_CH101 Module Connection (EV_MOD_CH101 acoustic port is facing down) 5

Figure 4. Dimensions of the EV_MOD_CH101 assembly 7

Figure 5. Recommended EV_MOD_CH101 module mounting 8

Figure 6. Beam pattern measurements of module in 100 mm plate (raw linear LSB units left, normalized dB right) 8

Figure 7. Beam pattern measurements of an EV_MOD_CH101 (w/o a mounting plate)..... 9

LIST OF TABLES

Table 1. EV_MOD_CH101 ZIF Connector Pin-Out..... 4

Table 2. Recommended Flat Flex Cable and Connector 5

Table 3. Bill of Material 5

Table 4. Geometric Dimensions for EV_MOD_CH101 7

1 SCOPE AND PURPOSE

This document details the specification, programming and operation of an EV_MOD_CH101-03-01 (referred to as the EV_MOD_CH101 in the remainder of this document) ultrasonic sensor evaluation module. The module board incorporates a CH101 Ultrasonic Sensor device with an omnidirectional acoustic housing assembly, a capacitor and an FPC/FFC connector. This evaluation module can perform pitch-catch and pulse-echo range-finding at distances from 4 cm to 1.2m. Several programming options are available for medium and short-range applications.



Figure 1. View of EV_MOD_CH101 evaluation module with an omnidirectional acoustic housing

2 EV_MOD_CH101 EVALUATION MODULE BOARD

2.1 PIN ASSIGNMENTS

PIN	NAME	DESCRIPTION
1	INT	Interrupt output. Can be switched to input for triggering and calibration functions
2	SCL	SCL Input. I ² C clock input. This pin must be pulled up to VDD externally.
3	SDA	SDA Input/Output. I ² C data I/O. This pin must be pulled up to VDD externally.
4	PROG	Program Enable. This pin must be pulled down to ground externally.
5	RESET_N	Active-low reset. This pin must be pulled up to VDD externally.
6	VSS	Power return.
7	VSS	Power return.
8	VDD	Power supply input. Connect to externally regulated 1.8V supply

Table 1. EV_MOD_CH101 ZIF Connector Pin-Out

2.2 ELECTRICAL SPECIFICATIONS

Please refer to DS-000331 CH101 Datasheet for information on the device’s electrical characteristics. Please note that the datasheet covers CH101 part numbers with different suffixes. Regardless, the electrical specifications in the datasheet still apply.

2.3 SCHEMATIC

Electrical connection to the EV_MOD_CH101 module is via an 8-pin 0.5 mm pitch flat flex cable (FFC) connector. Part numbers of the FFC connectors on the module PCB and the recommended FFC cables are shown in Table 2. The electrical schematic of the module, including the connector pinout and the connections to the EV_MOD_CH101 module, are shown in Figure 2. Note that the 0.1 μF decoupling capacitor, as recommended in the CH101 datasheet, is included in the module. Consult the CH101 datasheet and application notes for additional information on the electrical connections and operation.

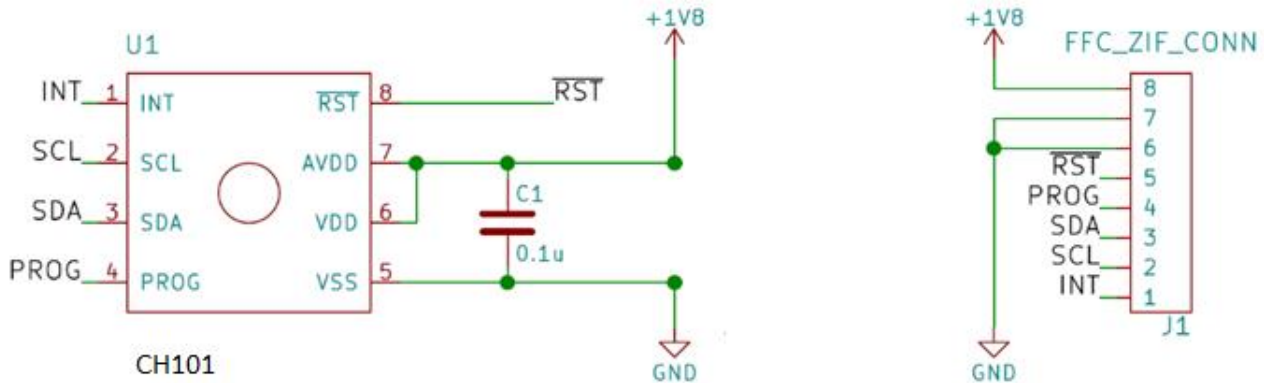

Figure 2. EV_MOD_CH101 Schematic

Each EV_MOD_CH101 requires its own PROG and INT lines, the remaining connections can be shared. Refer to the CH101 datasheet for additional information.

Module connections using a flat flex cable (FFC) are shown in Figure 3.

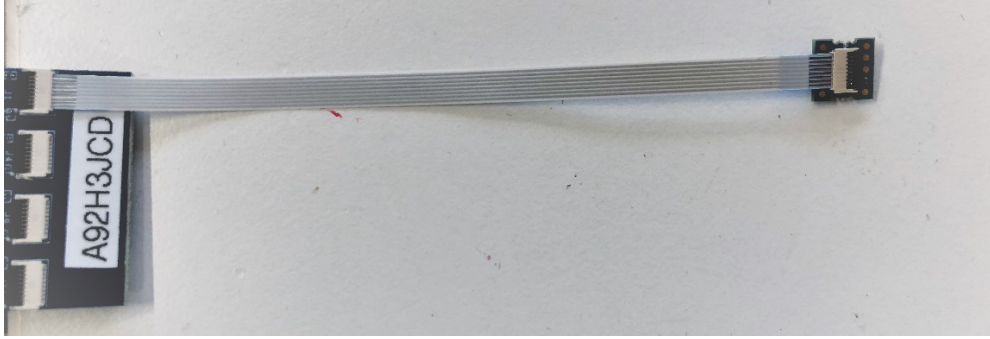

Figure 3. EV_MOD_CH101 Module Connection (EV_MOD_CH101 acoustic port is facing down)

FLAT CABLE CONNECTOR TYPE	Molex 503480-0800
RECOMMENDED FLAT CABLE	Molex 151660073...151660094

Table 2. Recommended Flat Flex Cable and Connector

2.4 BILL OF MATERIALS

QUANTITY	REFERENCE	PART	PCB FOOTPRINT	MANUFACTURER	MANUFACTURER PART NUMBER
1	PCB	PCB	NA		
1	U1	CH101-03	Custom – 8 Pin	TDK	CH101-03
1	C1	100n 6.3V 20% X7R 0402	0402	TDK	CGA2B1X7R1C104K050BC
1	J1	Connector, FPC-FFC, 8-Pin	8Pin, 0.5 mm Pitch	Molex	503480-0800

Table 3. Bill of Material

3 CONFIGURATION, PROGRAMMING, AND OPERATION

Please refer to DS-000379 CH101 Datasheet for information on the device's electrical characteristics.

3.1 CONFIGURATION AND PROGRAMMING

Please refer to the following documents for configuration and programming information:

- AN-000154 SmartSonic Hello Chirp Hands-On Document
- AN-000175 SonicLib Programmers Guide

3.2 OPERATION

Please refer to the following documents for operating information:

- AN-000155 CHx01 SonicLink Software Quick Start Guide
- AN-000180 CH101 and CH201 SmartSonic Evaluation Kit Users Guide

4 MECHANICAL SPECIFICATIONS

DIMENSION	EV_MOD_CH101	UNIT
Acoustic port hole	0.7	mm
Maximum width	8.15	mm
Module height	3.57	mm

Table 4. Geometric Dimensions for EV_MOD_CH101

The outer dimensions of the EV_MOD_CH101 assembly are shown in Figure 4. The acoustic port hole has a diameter of 0.7 mm and is in the center of the front face. During transducer operation, the port cannot be occluded or covered.

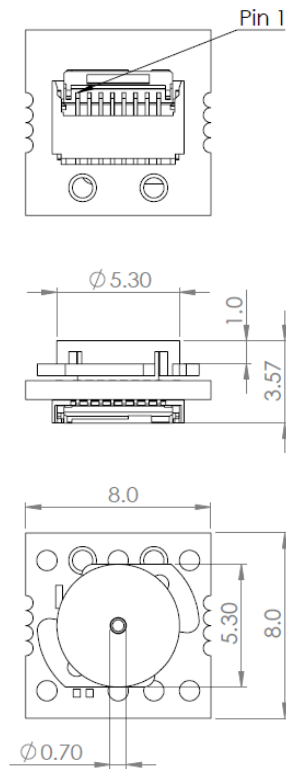

Figure 4. Dimensions of the EV_MOD_CH101 assembly

5 SENSOR MOUNTING AND BEAM PATTERNS

5.1 SENSOR MOUNTING

To achieve the best acoustic performance, users are recommended to mount the EV_MOD_CH101 module in a flat mounting plate. An example mounting plate is shown in Figure 5, where the sensor has been inserted into a 5.3 mm diameter hole has been drilled in a 1 mm thick plastic plate measuring 135 mm x 175 mm.

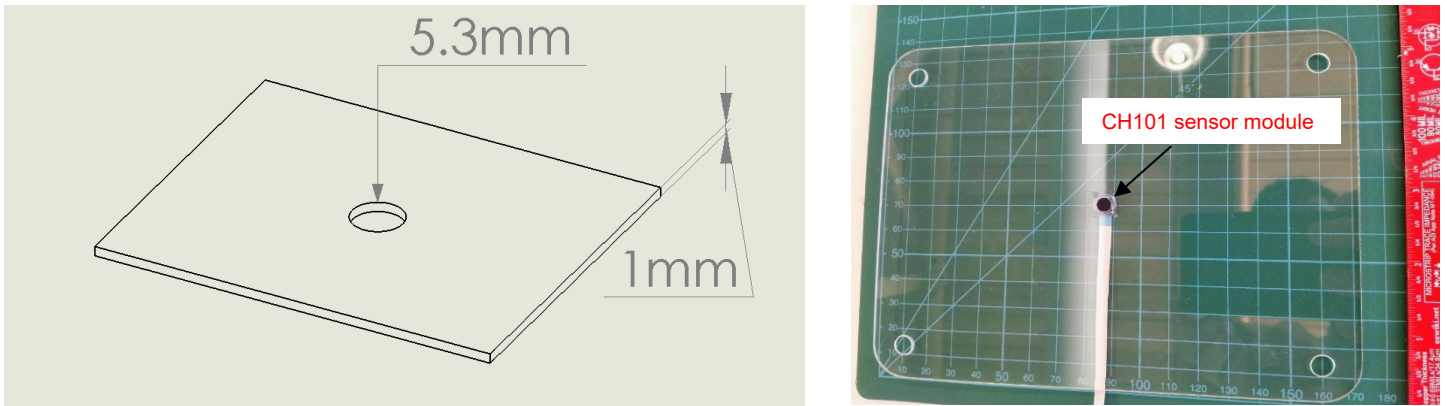

Figure 5. Recommended EV_MOD_CH101 module mounting

5.2 BEAM PATTERNS

Pulse-echo beam-pattern plots of the EV_MOD_CH101 module are shown in Figure 6. This beam-pattern was measured by placing a 1m² target at a 30 cm distance from the EV_MOD_CH101 module and recording the ToF amplitude as the sensor is rotated 180°. The plots are shown in both raw LSB units and normalized dB units, where 0 dB corresponds to the peak amplitude (5000 LSB) recorded on-axis. Chirp defines the field-of-view (FoV) as the full-width at half-maximum (FWHM) of the beam pattern; in other words, the FoV is the range of angles over which the amplitude remains above half the peak amplitude (or -6 dB). When mounted in the recommended plate, the sensor’s FoV is approximately 180° and the pulse-echo amplitude diminishes relatively smoothly from 0° to ±80°.

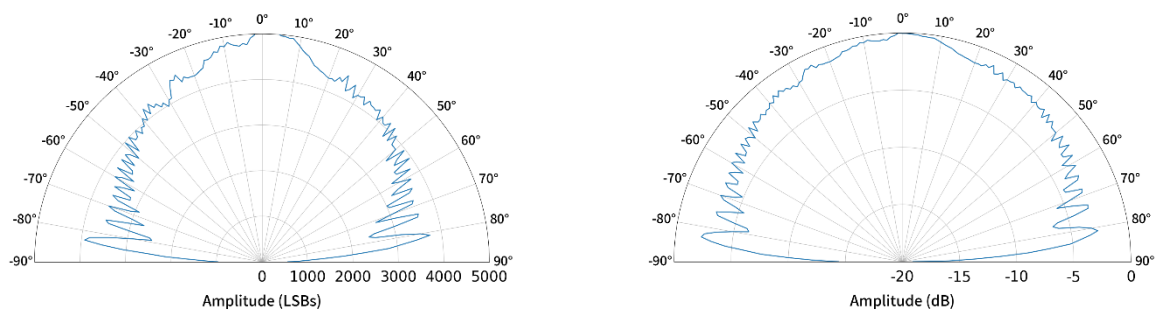

Figure 6. Beam pattern measurements of module in 100 mm plate (raw linear LSB units left, normalized dB right)

For comparison, the pulse-echo beam-pattern plot measured for an EV_MOD_CH101 when tested without a sensor mounting plate is shown in Figure 7. The beam pattern has three lobes: a main lobe and two side-lobes that are centered at $\pm 45^\circ$. The sensor device will work well for detecting on-axis targets, but targets located at $\pm 25^\circ$ will have approximately 70% lower (-10 dB) amplitude, possibly resulting in poor range-finding performance.

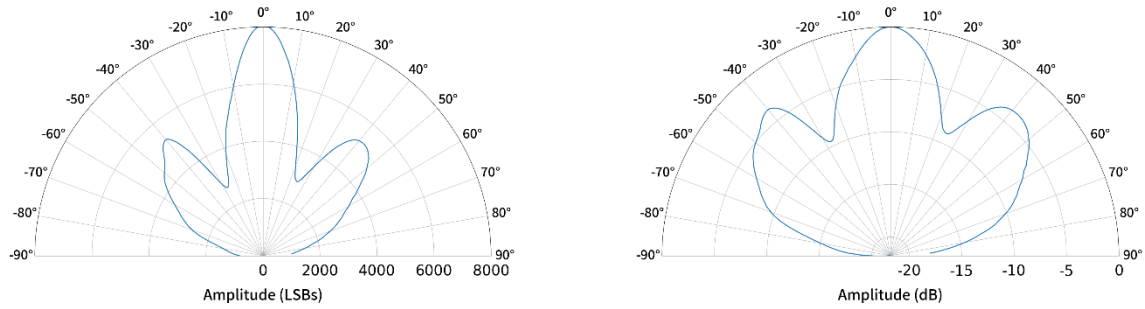

Figure 7. Beam pattern measurements of an EV_MOD_CH101 (w/o a mounting plate)
(raw linear LSB units left, normalized dB right)

6 REVISION HISTORY

REVISION DATE	REVISION	DESCRIPTION
08/18/2020	1.0	Initial Release

This information furnished by Chirp Microsystems, Inc. ("Chirp Microsystems") is believed to be accurate and reliable. However, no responsibility is assumed by Chirp Microsystems for its use, or for any infringements of patents or other rights of third parties that may result from its use. Specifications are subject to change without notice. Chirp Microsystems reserves the right to make changes to this product, including its circuits and software, in order to improve its design and/or performance, without prior notice. Chirp Microsystems makes no warranties, neither expressed nor implied, regarding the information and specifications contained in this document. Chirp Microsystems assumes no responsibility for any claims or damages arising from information contained in this document, or from the use of products and services detailed therein. This includes, but is not limited to, claims or damages based on the infringement of patents, copyrights, mask work and/or other intellectual property rights.

Certain intellectual property owned by Chirp Microsystems and described in this document is patent protected. No license is granted by implication or otherwise under any patent or patent rights of Chirp Microsystems. This publication supersedes and replaces all information previously supplied. Trademarks that are registered trademarks are the property of their respective companies. Chirp Microsystems sensors should not be used or sold in the development, storage, production or utilization of any conventional or mass-destructive weapons or for any other weapons or life threatening applications, as well as in any other life critical applications such as medical equipment, transportation, aerospace and nuclear instruments, undersea equipment, power plant equipment, disaster prevention and crime prevention equipment.

©2020 Chirp Microsystems. All rights reserved. Chirp Microsystems and the Chirp Microsystems logo are trademarks of Chirp Microsystems, Inc. The TDK logo is a trademark of TDK Corporation. Other company and product names may be trademarks of the respective companies with which they are associated.



©2020 Chirp Microsystems. All rights reserved.